

DATALOG X-PRO 2.0

INTERNET OF THINGS MULTI-SENSOR WIRELESS DEVICE

For LoRaWAN™, Sigfox, and GSM Networks

User's Manual



Version control

The following table contains the record of changes per manual version.

Version	Date	Description
1.6	14/06/2023	Format change. Extensive revision and correction of content. Technical background information update.
1.7	24/06/2023	Version control implemented.
1.8	30/10/2023	Certifications Sigfox/LoRaWAN.
1.9	30/10/2024	FCC Compliance Update

NOTICE

Read this manual before working with the product. For personal and system safety, and optimal product performance, make sure you thoroughly understand the contents before installing, using, or maintaining this product.

If you encounter a problem with your **Datalog X-PRO**, review the configuration information to verify that your selections are consistent with your application: input configurations; chosen limits; etc. If the problem persists after checking the above, you can have technical assistance at (+57) 3176478281, Monday through Friday, 7:00 a.m. to 5:00 p.m. Eastern Standard Time. You can also write to solutions@omicroniot.com, specialized personnel will discuss your application case.

Please have the following information available:

- All Configuration Information.
- All Provided Manuals.
- Device ID and the Parts List provided with the equipment.

Contact Information

To reach the **Datalog X-PRO** manufacturer for commercial information, refer to:

- Landline: +57 (604) 4087542
- Mobile: +57 (317)4365062
- comercial@omicroning.co

To reach the **Datalog X-PRO** manufacturer for technical information, refer to

- Landline: +57 (604) 4087542
- Mobile: +57 (317)6478281
- solutions@omicroniot.com

Visit us at: <https://omicroniot.com/>

Warning notice standard

This manual contains notices that must be observed in order to ensure personal safety, prevent damage to properties, and guarantee proper installation, use, and maintenance of the equipment.

The notices referring to personal safety or the integrity of the device are highlighted in the manual by an alert symbol; notes regarding recommendations or complementary information to the topics covered in this manual have no safety alert symbol. The notices shown below are graded according to the previous definitions.

Refer to the safety messages indicated by this standard at the beginning of each section before interacting with the device or its components:

⚠ WARNING

Indicates observations that, if not followed, could cause serious personal injuries, or damages to the device. The information in these tables indicates the risks related to each of the topics covered in this manual.



⚠ CAUTION

Indications on the correct use of the equipment, useful to avoid improper operation.



NOTE:

Recommendations and clarifications to take into account in the different topics covered in the manual.

Contents

Section 1: Introduction	8
1.1 Product Recycling / Disposal	8
1.2 Storage and transport	8
Section 2: Overview	9
2.1 Features	9
2.1.1 Standards compliance	10
2.2 Device configuration	10
2.3 Synchronization of data frames lost due to network failures	11
Section 3: Mounting Guidelines	12
3.1 Environmental Considerations	13
3.2 Dimensions	13
3.2.1 Main Unit Enclosure	13
3.2.2 Antenna	14
3.3 Mounting Indications	14
3.3.1 Main Unit	14
Section 4: Electrical Installation Foreword	16
4.1 Power Requirements	16
4.2 Electrical Ratings	16
4.3 Connection procedure	17
4.3.1 Indoor Use: Connection with AC/DC adapter (Supplied)	17
4.3.2 Outdoor Use: Connection to a Solar Panel or to an Industrial Power Supply (not provided)	18
Section 5: Introduction to device sensors	21
5.1 Sensor Types	21
5.2 Sensors Connection to the Datalog X-PRO	22
Section 6: Configuration	23
6.1 Normal Operating Mode	23
6.2 Alternative Device States	24
6.2.1 RF Test Mode	25
6.2.2 Send Data	25
6.2.3 Sleep/Off	26
6.2.4 Change the device from Sigfox to LoRaWAN™ mode	26
6.2.5 Change Sigfox Zone and LoRaWAN™ Regional Band	27
6.2.5.1 In Sigfox Mode	27
6.2.5.2 In LoRaWAN™ Mode	27
6.2.6 To reboot the device	27
Section 7: Configuration on Sigfox Backend	28
7.1 Callback configuration for Uplink Messages	28
7.2 Callback configuration for Downlink Messages	30
Section 8: Configuration on LoRaWAN™ TTN	33
8.1 Callback configuration for LoRaWAN™ Uplink Messages	33

8.1.1 Downlink API key	35
8.2 Format for Uplink payload	37
Section 9: Centriomega® Remote Control and Monitoring Platform	39
9.1 Access the Centriomega® Remote Monitoring Platform	39
9.2 Reviewing Historical Data	40
9.3 Reviewing Devices, their Variables, and Configuration	41
9.4 Reviewing Alarms and Programmed Events	43
9.5 Remote Configurator	44
9.5.1 Elements of the Remote Configurator	45
9.5.2 Use of the interface for remote configuration	45
Section 10: Troubleshooting Guide	47
10.1 I cannot access the remote monitoring platform	47
10.2 The device has stopped updating data on the monitoring platform	47
10.3 After forcing the device to send data, I cannot see the updates on the platform	48
10.4 When trying to save the configuration with the Remote Configurator, I see the message, "You do not have permission to perform this configuration. It is recommended to check the device ID entered, or the type of device selected."	49
10.5 I can't see the device ID on its label	49
Appendix A: Specifications and Reference Data	51
A.1 Specifications	51
A.1.1 Performance specifications	51
A.1.2 Functional specifications	51
A.1.3 Power supply	51
A.1.4 Communication	52

⚠ WARNING

Failure to follow safe installation guidelines could result in death or serious injuries.



- **Make sure the Datalog X-PRO is installed by qualified personnel** and in accordance with the applicable practice code.
- Use the device only as specified in this manual. Failure to do so may impair the protection provided by it.
- Inappropriate or incorrect use of the product may result in hazards and application-specific malfunctioning; such as damage to system components, due to incorrect mounting or adjustments.
- Do not perform any services besides those covered in this manual, unless you are qualified.
- Any substitution of non-authorized parts or repair, other than exchanging the sensors is prohibited.
- Unauthorized changes to the product are strictly prohibited as they may unintentionally and unpredictably alter the performance and safety.
- Unauthorized changes that interfere with the integrity of the enclosure or mounting holes, such as making additional perforations, compromise the product integrity and safety. **Equipment ratings and certifications are no longer valid on any products that have been damaged or modified without the prior written permission of Omicron IoT Solutions.** Any continued use of a product that has been damaged or modified without prior written authorization is at the customer's sole risk and expense.
- In case a replacement of the battery is required, make sure that it has the same reference, replacement of **battery** with an incorrect type can defeat the **safeguard**.
- Disposal of **battery** into a fire or a hot oven, or mechanically crushing or cutting of a **battery**, that can result in **explosion**.
- Leaving a **battery** in an extremely high temperature surrounding environment that can result in **explosion** or the leakage of flammable liquid or gas.
- A **battery** subjected to extremely low air pressure that may result in **explosion** or the leakage of flammable liquid or gas.

Explosions could result in death or serious injuries.

- Verify that the operating environment of the device is consistent with its environmental specifications.
 - **This device is not intended for use in flammable or combustible atmospheres.**
-
-

Section 1: Introduction

This reference manual provides detailed product related information, installation, setup, and operation instructions for the Datalog X-PRO. **The manual is designed for trained personnel. Read it entirely and carefully before installing and setting up the product.**

⚠ WARNING

The procedures and instructions in this manual may require special precautions to ensure the safety of the personnel performing the operations. The information that raises potential safety issues is indicated by a warning symbol. Refer to the safety messages listed at the beginning of each section before performing an operation preceded by this symbol.



1.1 Product Recycling / Disposal

Recycling of device components and packaging should be taken into consideration and disposed of in accordance with local and national legislation/regulations.

The battery must be properly disposed of according to local regulations and the recommendations presented in the warnings section.

1.2 Storage and transport

The **Datalog X-PRO** is protected by a special packaging during transport and is guaranteed to handle normal loads during transport.

Section 2: Overview

The internet of things (**IoT**) multisensor wireless device **Datalog X-PRO** is designed for remote monitoring of multiple processes requiring high safety and measurement precision. In support of your automation needs, **it is fitted to receive up to 3 sensors of multiple types** (listed in Section 5).

The system is delivered with a rechargeable Li-Ion Battery, accessories needed to mount the Main Unit enclosure, its AC/DC adapter, and a wireless communication module. Remote data transmission may be performed by different popular wireless technologies. Customers are also offered memberships for the use of a platform for remote monitoring and configuration of the device, supported by the manufacturer. More details on this can be found further below. The use of other user-preferred monitoring platforms is also supported.

The device is delivered with the necessary tools for its installation in the user's application. It may require initial configuration regarding its wireless communication configuration. After the first setup, additional configurations can be made remotely.

2.1 Features

The **Datalog X-PRO** has been thought to be easily implemented and to monitor and deliver data about the evolution of the processes it is in. For this, it relies on a series of parameters, functionalities, and tools; among these, it is worth highlighting the direct link that the devices have with the Centriomega® Remote Monitoring Platform through their wireless communication modules: a platform accessible from any computing device enabled for internet navigation (PC, tablet, smartphone).

Said platform enables remote device configuration and monitoring, shows real-time dashboards with the variables of interest, presents alarms with visual indications, sends external warning messages through email, SMS, and Telegram messages or via webhooks, keeps data registers for up to two years, and tracks corrective actions and comments taken when alarms have occurred.

Relevant features include:

- Communication port, where a dual communication module with protocols for LoRaWAN™/Sigfox for the USA/EU/Latam/Australia zones or a GSM wireless transmission module can be installed.
- Ports for three (3) sensors.
- Rechargeable Li-Ion battery.
- IP67 protection.
- Connected to a web platform for remote monitoring via PC, Tablet, or Smartphone.
- Historical data records on the **Centriomega® Remote Monitoring Platform**.
- Email, SMS, voicemail, Telegram, and Webhook notifications.
- In LoRaWAN™ mode, it temporarily stores up to 140 messages, in case of network connection failure.
- Remote parameters configuration.

2.1.1 Standards compliance

The **Datalog X-PRO 2.0** has been tested for the **Sigfox and LoRaWAN** models, for electromagnetic compatibility, operational testing, RF exposure, and electrical safety, under the following standards and tests:

- **EMC (Electromagnetic Compatibility):**
 - FCC: 47 CFR Part 15B / ICES-003 Issue 6 1.00
 - EN 301 489-1 + EN 301 489-3
- **Sigfox and LoRaWAN operational test:**
 - EN 300 220-1 + EN 300 220-2
- **RF exposure:**
 - EN 62311:2020
- **Electrical safety:**
 - EN 62368-1



Compliance statement - Datalog X-PRO 2.0

Contains FCC ID: 2AS8LLSM110A

This equipment has been tested and found to comply with the limits for a class B digital device, pursuant to part 15 of the FCC Rules. These limits are designed to provide reasonable protection against harmful interference in a residential installation. This equipment generates, uses and can radiate radio frequency energy and if not installed and used in accordance with the instructions, may cause harmful interference to radio communications. However, there is no guarantee that interference will not occur in a particular installation. If this equipment does cause harmful interference to radio or television reception, which can be determined by turning the equipment off and on, the user is encouraged to try to correct the interference by one or more of the following measures:

- *Reorient or relocate the receiving antenna.*
- *Increase the separation between the equipment and receiver.*
- *Connect the equipment into an outlet on a circuit different from that to which the receiver is connected.*
- *Consult the dealer or an experienced radio/TV technician for help.*

This device complies with Part 15 of the FCC Rules. Operation is subject to the following two conditions: (1) This device may not cause harmful interference, and (2) this device must accept any interference received, including interference that may cause undesired operation.

Responsible Party – U.S. Contact Information

3SENSE TECHNOLOGY LLC
19391 SW 15 ST Encantada
Pembroke pines
33029
Tel: 7865847439

2.2 Device configuration

It is possible to remotely configure the parameters of each sensor and the device, such as alarm limits, data publication time, among others. This can be done through a remote configuration platform, for which the Web IoT monitoring platform offered with the device (Centriomega®) already includes this (Refer to **Section 9.5** for more details).

However, if you want to do this on your own platform, please refer to the **Communication Protocol Manual** to learn how to interpret the data frames sent by the Datalog X-PRO device and how to send remote configuration messages to it. To do this, the application software

must be able to **send or store configuration messages, which must have the following fields:**

- ID of the device to which the message is addressed.
- Identification of the sensor.
- Parameter to be modified.
- Value or data.

The information that travels through the Internet is encrypted through secure and certified protocols to prevent it from being seen, manipulated or supplanted by third parties.

2.3 Synchronization of data frames lost due to network failures

The **Datalog X-PRO** devices also have a real time clock (RTC) system and the ability to synchronize this clock through communication with the software service, in such a way that it can store as a backup the last 140 messages sent, with a correct time stamp. Thanks to this, if there are data frames lost due to network failures, they can be automatically recovered when the connection is re-established through an encoded message type from the server.

Note: This feature only operates for devices with LoRaWAN™ modules.

Section 3: Mounting Guidelines

To properly mount the device, please consider the instructions and suggestions given in the following chapters. Plan all wiring before installing the **Datalog X-PRO**. Also consider the cabinet space, hardware dimensions, and rated environmental conditions. Use good wiring practices to minimize problems that may occur due to electrical interference.

⚠ WARNING

Make all electrical connections with the equipment disconnected from the main power source, this could result in damage to the device or the sensors.



The Main Unit enclosure is a standard ABS plastic box, with brackets for pole mounting, or covered perforations for wall mounting; its details are given in Section 3.2.1.

NOTE:

The system should be installed with all peripherals attached, to mount the assembly as a single block. It is strongly recommended to install the antenna so that its axis is vertical with respect to the ground, as this favors the range of the signals transmitted by the device.

Consider clearing a square area, of 25 cm at each side, of the plane in which the Datalog X-PRO needs to be installed. Mount the system near the center of said clear space, to leave enough margins to comfortably install its peripherals, as shown below:



Figure 3-1 Recommended free space around the Datalog X-PRO

3.1 Environmental Considerations

The device’s Main Unit and sensors are suited to be used in indoor/outdoor locations, since enclosures are generally offered with IP67 protection: as such, they’re waterproof and dust-proof, as well as UV resistant. Environmental limits set for its operation are as follows:

- Altitude up to 2600 m.
- Temperature: 5°C to 40°C (41°F to 104°F)
- Maximum relative humidity: 100%
- Pollution degree: 3

⚠ WARNING

- **Locate the Datalog X-PRO and all related components away from AC power/motor wiring and direct heat output sources such as transformers, heaters, large capacity resistors, or shock and vibration sources.**
- **Don't use the device in areas where chemicals or flammable gasses are present to minimize any risk of ignition.**



3.2 Dimensions

3.2.1 Main Unit Enclosure

The Main Unit enclosure is a standard ABS squared plastic box for electronics. Its dimensions are illustrated below:

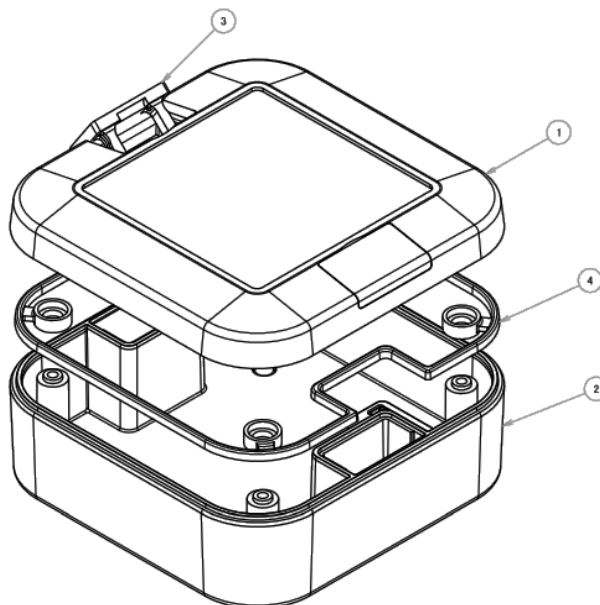

Figure 3-2 Main Enclosure elements

Datalog X-PRO enclosure elements	
1	Top cover
2	Bottom base
3	Blind lids
4	Gasket

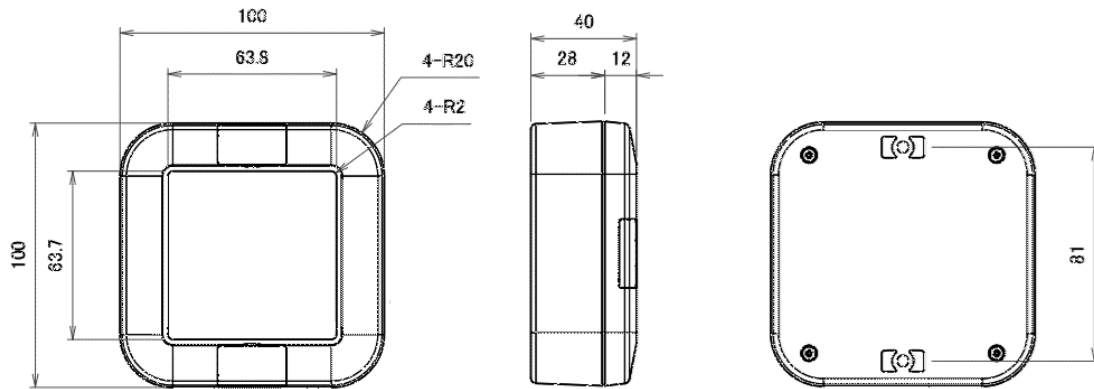

Figure 3-3 Main Enclosure Dimensions

Dimensions in mm. Dark Gray enclosures made from ABS UL94-V0 plastic for high flammability rating (most flame retardant).

3.2.2 Antenna

The system uses an external helical antenna for a frequency range: 868-915MHz. This peripheral component requires the most amount of clear space around. Its dimensions are shown in the Figure 3-4:

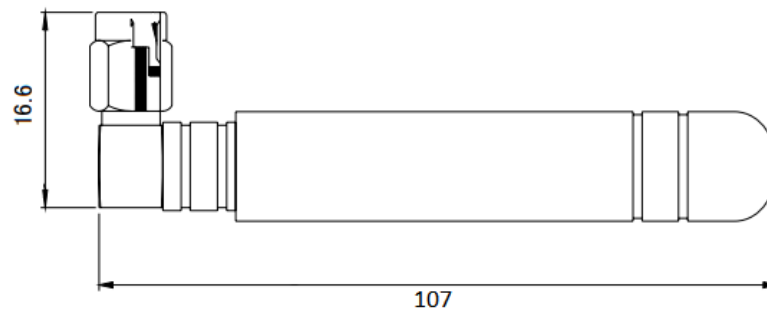

Figure 3-4 Antenna Dimensions (in mm)

3.3 Mounting Indications

3.3.1 Main Unit

To secure the Main Unit enclosure to a wall:

1. Find the mounting holes covered by the blind lids at the top and bottom borders of the Main Unit enclosure. They might be easier to locate after reviewing section 3.2.1.
2. Prepare the surface on which the Main Unit will be placed, taking into account the distance between the holes previously found (which is 81mm).
3. Use M3 screws (nuts, washers, or plastic anchors, as needed) to fix the device where it is required.

To mount the Main Unit on a pole:

1. Find the mounting holes covered by the blind lids at the top and bottom borders of the Main Unit enclosure. This might be easier after reviewing the previous section.

2. Attach the pole mounting bracket accessories that come with the delivery to the Main Unit, using the screws provided by the manufacturer.
3. Finally, fasten the Main Unit to its pole using proper mounting straps.



Figure 3-5 Reference example of a similar device mounted on a pole

NOTE:

- Remember that, since the Datalog X-PRO operates with sensors and accessories attached, **it is recommended to leave enough space around the Main Unit to let it hold its peripherals comfortably.**
 - Avoid placing the device inside metal cabinets or near metal structures and columns, this may reduce the radiation pattern of the device and damage the communication ability of the **Datalog X-PRO.**
-

Section 4: Electrical Installation Foreword

Consider implementing safeguards independent of the **Datalog X-PRO** when designing the wiring and grounding plans for your application. This could help to assure optimum system operation, provide additional electrical noise protection for your application and the **Datalog X-PRO**, and prevent any malfunction in the process due to unexpected failures, to which any electronic system is susceptible.

4.1 Power Requirements

Among other hardware and firmware protections, the **Datalog X-PRO** is protected against power interruptions with its battery; which can provide power for up to 180 days (depending on the sensors implemented and the uplink period to the remote monitoring platform), aiming to keep safe monitoring and storage of data. Thanks to this, the user may consider using the device without connecting it to a power source in combination with the sensors that allow it, and recharge the battery whenever it is necessary.

⚠ CAUTION

Always observe the following safety instructions:



- Connections must be made only in the complete absence of line voltage.
- If over-voltage is expected, surge arresters should be implemented by the user.
- **The power adapter delivered with the device is only for indoor use.** Use only UL, CSA, CE, or EN safety-certified power adapters or an Industrial Power Supply with dual insulation between its primary and output for powering the **Datalog X-PRO**. The power supply output rating must be limited to 12VDC/0.5A or 24VDC/0.25A for a single **Datalog X-PRO**.
- **For outdoor use, the user could use a UL, CSA, CE, or EN safety-certified and waterproof-approved power supply or a solar power system** (not provided); the output rating must be limited to 12VDC/0.5A or 24VDC/0.25A for a single **Datalog X-PRO**.

In any case, a 12VDC/0.5A 6W or 24VDC/0.25A 6W fuse and circuit breakers should be used between the power supply and the device.

4.2 Electrical Ratings

Main Unit Ratings:

- **Rated main input voltage:** 12 to 24 VDC.
- **Max. Electric Current:** 0.5A@12VDC or 0.25A@24VDC.

AC/DC Adapter Ratings (Provided only for Indoor use):

- **Input:** 100 ~ 240VAC (Nominal: 110 to 220 VAC \pm 10 %), 47 ~ 63Hz (Nominal: 50 to 60 Hz), 0.5A - 100VAC.
- **Rated Output:** 12VDC \pm 2%, 1 A.
- **Power Rating:** Max. 12W @12VDC.

⚠ WARNING

Exceeding the voltage ranges related to the power supply could cause damage or unpredictable operation, which could result in death or severe personal injuries and/or property damages. To avoid any risk, the Datalog X-PRO manufacturer could be reached to receive further assistance on how to properly connect the device. Remember that the Contact Information is provided at the beginning of this document.



4.3 Connection procedure

⚠ CAUTION

- Connections must be made only in the complete absence of line voltage.
- **It is recommended to use UL, CSA, CE, or EN safety-certified products for connections and electrical protection.**
- Use only UL, CSA, CE, or EN safety-certified power adapters or an Industrial Power Supply with dual insulation between its primary and its output for powering the Datalog X-PRO. The power supply output rating must be limited to 12VDC/0.5A or 24VDC/0.25A for a single **Datalog X-PRO**.



The Datalog X-PRO is provided with a terminal connected to its internal power circuit; so the user can connect a 12 to 24 VDC power supply or a Solar Panel with the adequate terminal. Alternatively, and only for indoor use, the user can connect the device to a 12VDC power adapter (supplied). Follow the next directives for the different options.

4.3.1 Indoor Use: Connection with AC/DC adapter (Supplied)

1. Connect the adapter's male plug to the female socket (See Figure 4-1).
2. Connect the power adapter to a wall mains electricity 110 VAC-220 VAC, 50-60Hz.



Figure 4-1 AC/DC Adapter Connection

4.3.2 Outdoor Use: Connection to a Solar Panel or to an Industrial Power Supply (not provided)

⚠ WARNING

- Review diagrams thoroughly before the installation. Support in electrical wiring handbooks, or have your device connected by a qualified licensed electrician.
- All electrical connections must be in accordance with local codes and ordinances. If you are unfamiliar with methods of installing electrical wiring, secure the services of a qualified electrician.
- If the total power consumed by the sensors connected to the Datalog X-PRO is greater than 6 watts, the user must power the sensors directly from the power supply instead of the Datalog X-PRO ports. Please contact Omicron IoT Solutions for assistance if you have any special requirements.



1. Connect the power cable terminal of the Datalog X-PRO to the output of a **12VDC/0.5A 6W or 24VDC/0.25A 6W fuse and/or circuit breaker** suited for outdoor use, and these to the power supply.

Table 4-1 Datalog X-PRO Connections

Wire Color	Description
Red	Positive power supply
Black	Negative power supply

The following image illustrates how to connect the referred protection and disconnection elements to the Datalog X-PRO and the solar panel:

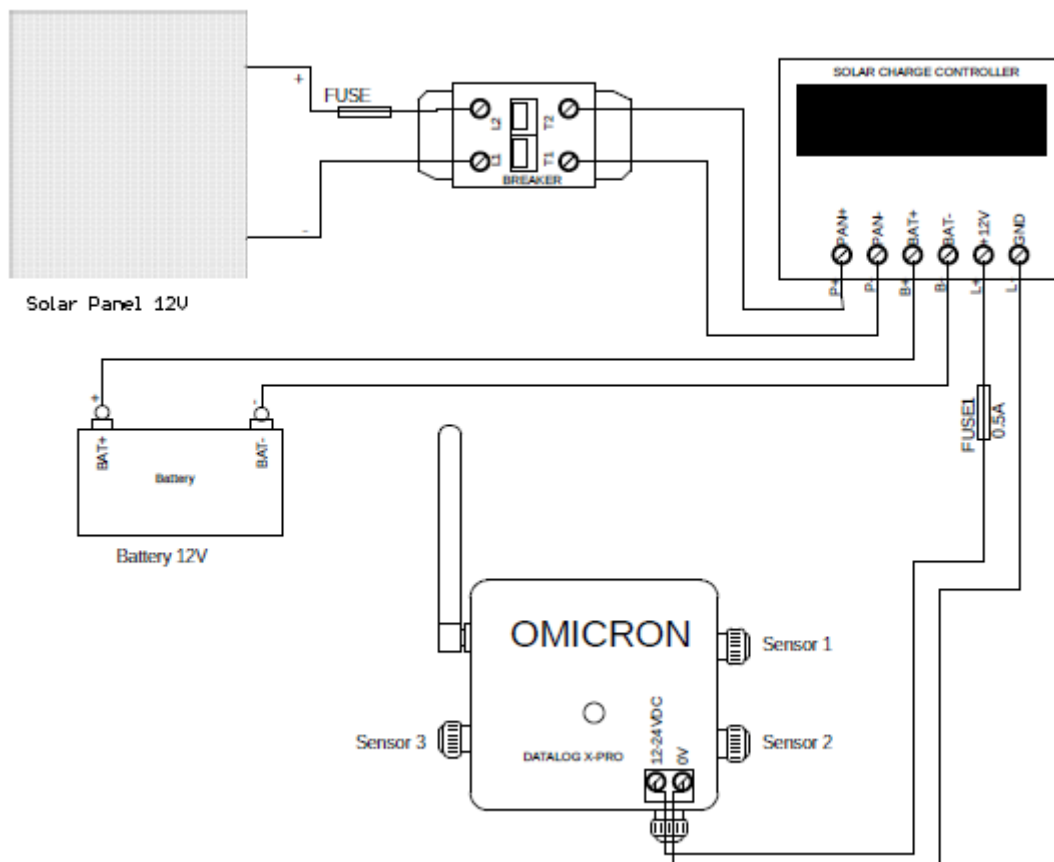

Figure 4-2 Schematic of Installation of the Datalog X-PRO with a Solar Panel System

2. Follow the guidelines of the solar panel and solar charge controller device manufacturers for their mounting:

- Calculate the total power of the system adding the power of the individual sensors connected to the Datalog X-PRO.
- Calculating the power of the solar panel and battery depends on the solar radiation present at the installation place.
- Calculate the value of the fuse and the primary breaker to protect the system depending on the energy generated by the solar panel and the recommendations given by the manufacturers of the solar panel and the solar charge controller.

3. Loosen the terminal block screws located inside the Solar Panel terminal box.

4. Connect the Breaker and the Fuse to the primary circuit, between the Solar Panel and the Solar Charge Controller.

NOTE:

It is recommended to install the Datalog X-PRO below the Solar Panel (See Figure 4-3), since this can prevent overheating of the device caused by direct sunlight over it.

It is recommended to cover the terminal box of the solar panel with a layer of silicone after mounting and connecting it, to ensure its protection against the ingress of water or dust.

Remember that the protection elements must be suitably located and easily reachable. Also, said components must be marked as the disconnecting mechanism from an external power source for the monitoring system.

⚠ CAUTION

To avoid the overheating of Datalog X-PRO caused by solar radiation directly over it, it is recommended to install the device vertically and in the shadow of the solar panel (See figure 4-3).

Make sure that the IP67 protection of the Solar Panel or the Datalog X-PRO does not get affected or impaired by the mounting.



Figure 4-3 Reference installation of the Datalog X-PRO with a Solar Panel

Section 5: Introduction to device sensors

5.1 Sensor Types

There are more than 60 different sensors that the user can connect to the **Datalog X-PRO**. **One device can receive up to three different sensors** communicating with the main unit through their sensor interfaces.

NOTE:

Other types of sensors can be ordered, for more information on sensor customization please contact us.

The sensors selected can be used to measure multiple and different variables, and be implemented in different use cases. Shown below is a list of possible applications; related to sensors for different variables:

Table 5-1 Datalog X-PRO Sensors Applications

Purpose	Related Sensors
Measurement of industrial Signals: Industrial Applications	<ul style="list-style-type: none"> → Temperature and humidity → Pressure and flow → Analog Signals: 4-20 mA/0-10 V for different types of sensors and transmitters. → Digital Modbus RTU signals. → CO, CO2, O2, transmitters. → Digital (dry contact signals)
Security monitoring in private spaces: which require presence sensors, smoke sensors, or door or window opening sensors.	<ul style="list-style-type: none"> → Temperature + Humidity + Pressure → Luminosity → Presence - PIR (Digital Signal) → Smoke Sensor (Relay Output) → Air Quality Sensors: CO, SO2, NO2
Measurement of variables in early warning systems.	<ul style="list-style-type: none"> → Ultrasound or radar distance sensors (0 to 30 meters) → Air Quality Sensors: CO, CO2, SO2, NO2 → PM 1.0, PM 2.5, and PM 10
Measurement of meteorological variables: in weather stations and Precision Agriculture	<ul style="list-style-type: none"> → Temperature, Humidity, Pressure → Luminosity → UV Radiation → Rain gauge → Wind Speed and Wind direction → 7 in 1 Weather station

Measurement of water Quality: in fish farms and water treatment plants	<ul style="list-style-type: none"> → Dissolved Oxygen → Temperature → PH → Ions: NO3, NH4, CL-, Na+ K+ → Water Turbidity
---	---

5.2 Sensors Connection to the Datalog X-PRO

NOTE:

A sensor can be installed in any of the three Datalog X-PRO ports, however, once the installation is complete, it is necessary to relate them to the Monitoring Platform. For that reason, once the configuration is done, avoid changing any sensor to another port, as this could cause confusion and erroneous readings on the monitoring platform.

1. Align the marked guide on the sensor cable with the port.
2. Push gently into the connector until it bottoms out.
3. Screw the sensor so that it is fixed.
4. Pull slightly on the sensor and check that the sensor is securely attached to its port.



Figure 5-1 Sensor Connection

Section 6: Configuration

6.1 Normal Operating Mode









The Datalog X-PRO is delivered in Sleep/off State. To wake it up for the first time, join the magnet provided one time near the main unit top cover (See Figure 6-1); after this, the system will automatically enter in Normal Operating Mode, which can be recognized by checking the LED on the top cover of Main Unit's enclosure (LED Indicator, from now on); if it flashes blue sporadically (almost, once a minute), the device reports correct operation. Also, in Normal Operating Mode, as long as a magnet is placed near the Main Unit, as described in Figure 6-1, the LED Indicator will shine red.

NOTE:

The LED Indicator will flash blue, green, red, or purple to show that the device is reading sensors, configuring its Communications Module, sending data, or accepting a command. Refer to Table 6-1 to understand the proper Datalog X-PRO LED Indicator operation.

If the device is busy, for example trying to send data or trying to connect to the network, it cannot receive any settings. **In these cases, the LED Indicator will remain on until the device finishes executing the action it is performing and becomes available to receive another configuration via the magnet. Therefore, if the device does not respond to the magnet, please wait until you notice that there is no LED activity for more than 30 seconds.**

Table 6-1 Front Panel LED Indicator

Function		Led Operation
Sensor reading		Three short blue flashes
Configuring the communication module		Short green flashes
Sending data to the Internet	 	Two to four one-second green or green yellow flashes See Section 6.2.2
Manual configuration action		Red flash
In RF test mode		Short every five seconds red flashes
Accepting/Confirming a command		Short violet flashes
Receiving a downlink message		Two short white flashes

From Normal Operating Mode, users can take the device to several alternative states using the magnet provided with the device (or any similar neodymium magnet). Access to said states is performed after briefly, and on several times, joining such magnet between the Sensor 1 and Sensor 2 ports, as shown in the following image:



Figure 6-1 Proper position to locate the programming magnet near the Datalog X-PRO

6.2 Alternative Device States

While in Normal Op. Mode, as long as a magnet is placed near the Main Unit, as described before, the LED Indicator will shine red.

Depending on the number of times the magnet is briefly brought close to the Main Unit, users can reach one of the alternative states indicated in Figure 6-2.

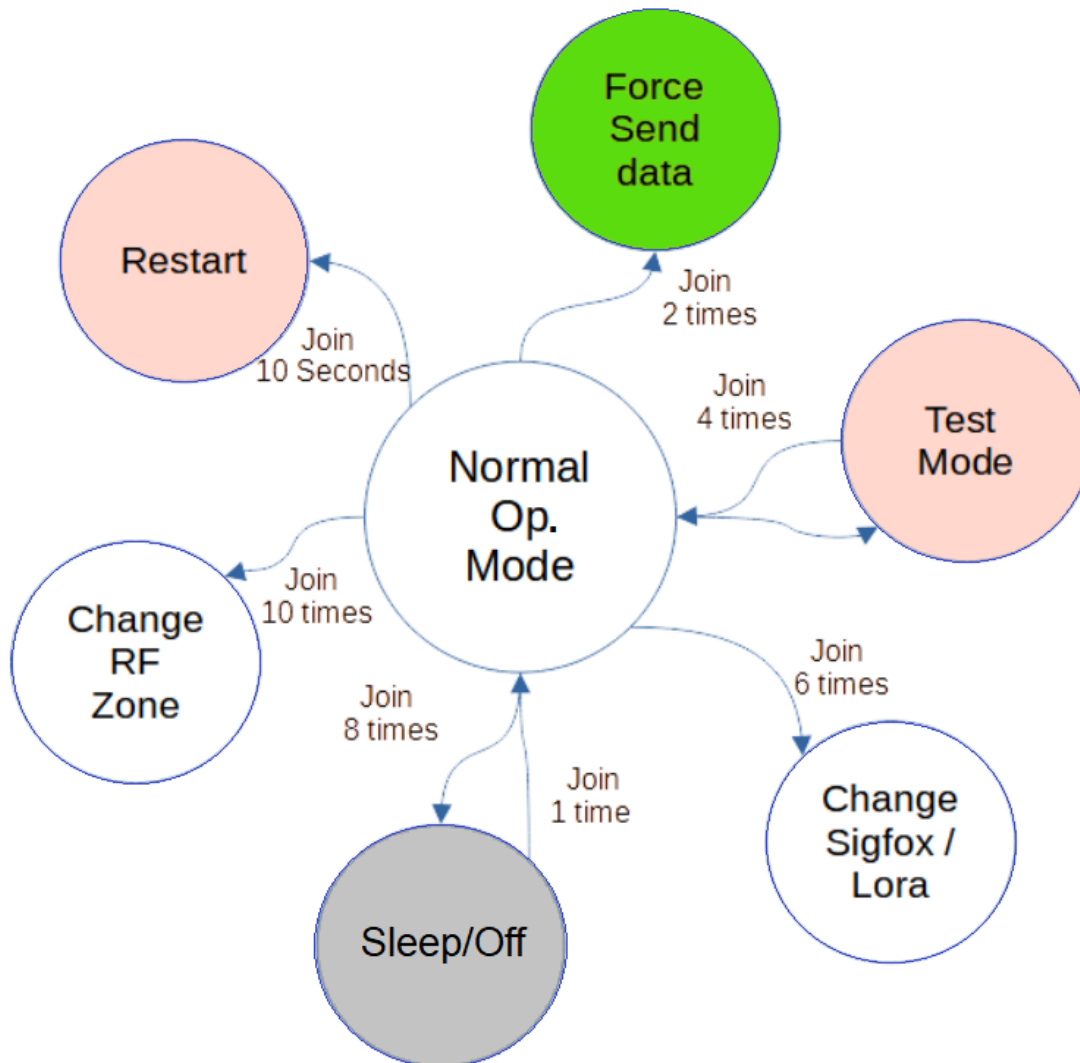

Figure 6-2 Alternative Device Operating States

6.2.1 RF Test Mode

To enter in the RF test Modes (Please refer to “**Service and Maintenance Manual for the Datalog X-PRO**”), it’s necessary to briefly join a magnet near the main unit 4 times.

After approaching the magnet as indicated, the LED Indicator will light violet 4 times to indicate that the device is about to enter the RF Test Mode. **Once the device has entered this mode, the LED indicator will flash red every five seconds.**

When quitting this mode, after briefly joining a magnet near the main unit 4 times, the LED Indicator will light violet 4 short times.







6.2.2 Send Data

The configured publication time for each sensor will naturally limit the data transmissions executed by the **Datalog X-PRO**. However, **the device may be forced to send its readings after briefly joining a magnet near the Main Unit 2 times.**

When the Datalog X-PRO sends data, the LED Indicator will flash blue to show that it is reading its peripherals, and then it will flash green or yellow-green depending on the zone

and protocol configured (See **Table 6-2**). After this, the LED will stay on while the device finishes sending the data.

Table 6-2 Front Panel LED Indicator in Sending Mode

Function: Sending Data	Led Operation
LoRaWAN™ Protocol	
USA915 band	 2 green flashes
EU868 band	 3 green flashes
AU915 band	 4 green flashes
Sigfox Protocol	
RCZ2 USA, Mexico, Brazil Zone	 2 green-yellow flashes
RCZ1 EU Zone	 3 green-yellow flashes
RCZ4 LATAM, AU Zone	 4 green-yellow flashes

6.2.3 Sleep/Off

The device can access Sleep/Off State after **briefly joining a magnet near the Main Unit 8 times**. In this mode, the device stops reading and sending data; which minimizes battery consumption.

After approaching the magnet as indicated, the visual indicator will light violet 8 times to indicate that the device is about to enter in Sleep/Off State.

To quit this mode, briefly place a magnet near the Main Unit 1 time.

6.2.4 Change the device from Sigfox to LoRaWAN™ mode

NOTE:

For proper operation, select the correct **Datalog X-PRO** model depending on the Sigfox Zone coverage and LoRaWAN™ Band.

Datalog X-PRO 2.0 USA

USA, Mexico, Brazil: Sigfox Zone 2 and LoRaWAN™ US915.

Latin America and Australia: Sigfox Zone 4 and LoRaWAN™ AU915.

Datalog X-PRO 2.0 EU

Europe: Sigfox Zone 1 and LoRaWAN™ EU868.

To change the Communication Module Operation Mode between **LoRaWAN™** and **Sigfox**, **briefly join a magnet near the Main Unit 6 times**. After this, the device will respond with its LED Indicator.

Table 6-3 Panel LED Indicator when changing from Sigfox to LoRaWAN™

Function	Led Operation
If the device enters Sigfox Mode	 2 violet flashes
if the device enters LoRaWAN™ Mode	 3 violet flashes

6.2.5 Change Sigfox Zone and LoRaWAN™ Regional Band

Only for the model **Datalog X-PRO 2.0 USA**, to configure the zone in which the device operates, **briefly join a magnet near the Main Unit 10 times**. After this, the device will respond with its LED Indicator.

Table 6-4 Panel LED Indicator when changing Regional Band or Zone

Function		Led Operation
If the device enters in Sigfox RC2 or LoRaWAN™ Band US915		2 violet flashes
If the device enters in Sigfox RC4 or LoRaWAN™ Band AU915		4 violet flashes

6.2.5.1 In Sigfox Mode

If the LED Indicator flashes violet 4 times, the device is being set to work in zone 4 of the network; on the other hand, if the LED flashes twice, it is to show that the device will be configured to operate in zone 2 of the network.

6.2.5.2 In LoRaWAN™ Mode

If the LED indicator flashes violet 2 times, the device is being set to work in the US915 Band, and if the LED flashes 4 times, it is to show that the device will be configured to operate in the AU915 Band.

NOTE:

After the **Datalog X-PRO** displays the response to a command with violet LED flashes, then the device continues with the configuration of the communication module. Remember that the LED indicator will remain green with a few intermittent flashes indicating that the device's internal communication module is being reconfigured (See **Table 6-1**).

6.2.6 To reboot the device

To reboot the device, hold the magnet near the device for 10 seconds until the LED shows violet. The device will then start with blue and green flashes indicating the initialization status.

Section 7: Configuration on Sigfox Backend

If it is desired that the **Datalog X-PRO** devices work with the Omicron IoT Solutions Monitoring Platform using the Sigfox Telecommunications Network, the user can enable bidirectional communication with the platform by associating Callbacks to the Uplink and Downlink messages from the devices in the **Sigfox Backend**.

NOTE:

For proper operation select the correct Sigfox Module configuration in the **Datalog X-PRO** (see sections 6.2.4 and 6.2.5) depending on the Sigfox Zone coverage.

Datalog X-PRO 2.0 USA

USA, Mexico, Brazil: Sigfox Zone 2.

Latin America and Australia: Sigfox Zone 4.

Datalog X-PRO 2.0 EU

Europe: Sigfox Zone 1.

Uplink-Downlink protocol for third-party platforms:

If you want to use another monitoring platform, please don't hesitate to contact us and ask for the **Communication Protocol Manual** for the Datalog X-PRO.

7.1 Callback configuration for Uplink Messages

Follow the next steps for the configuration of Callbacks in the Sigfox Backend, for Sending Data to the Omicron IoT Solutions Platform.

1. In the Sigfox backend, enter the device type to which you have associated the Sigfox modules used by your Datalog X-PRO devices, and select CALLBACKS from the menu on the left.

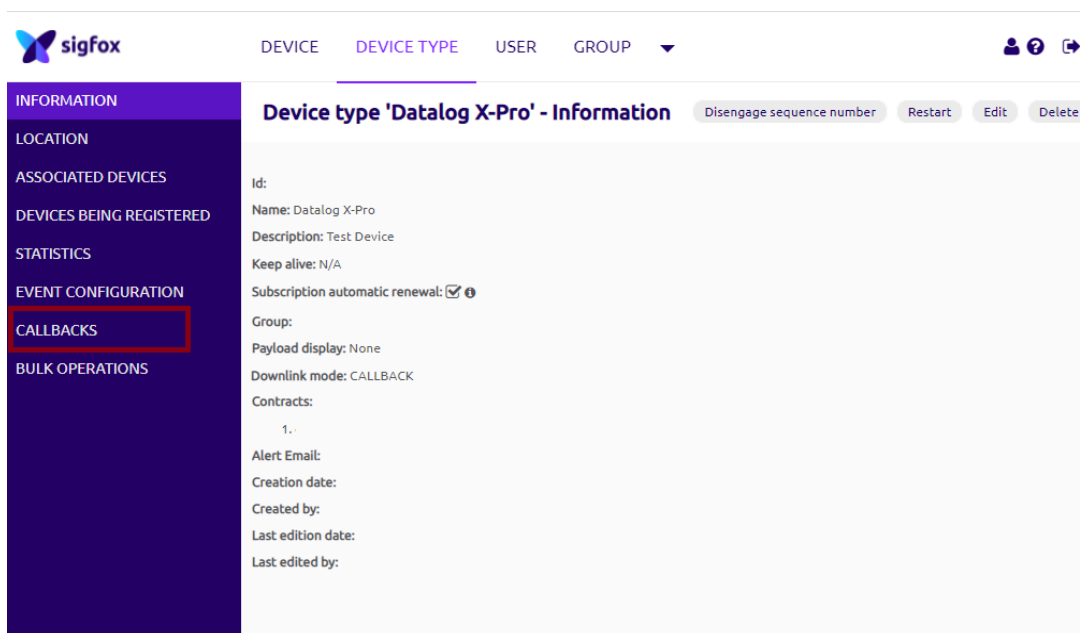

The screenshot shows the Sigfox backend interface. The top navigation bar includes 'DEVICE', 'DEVICE TYPE', 'USER', and 'GROUP'. The left sidebar has a menu with 'CALLBACKS' highlighted. The main content area is titled 'Device type 'Datalog X-Pro' - Information' and contains the following fields:

- Id:
- Name: Datalog X-Pro
- Description: Test Device
- Keep alive: N/A
- Subscription automatic renewal:
- Group:
- Payload display: None
- Downlink mode: CALLBACK
- Contracts:
 - 1.
- Alert Email:
- Creation date:
- Created by:
- Last edition date:
- Last edited by:

2. Create a new callback.

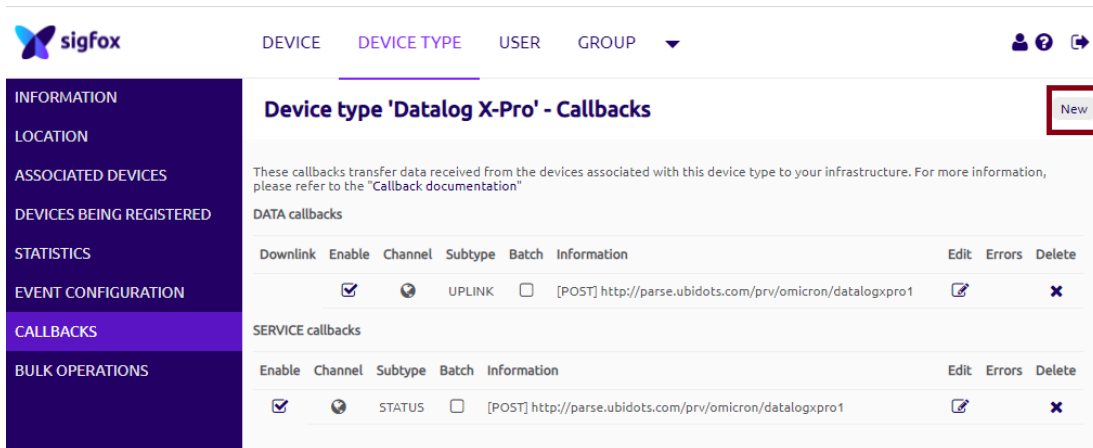

3. Select "Custom Callback".

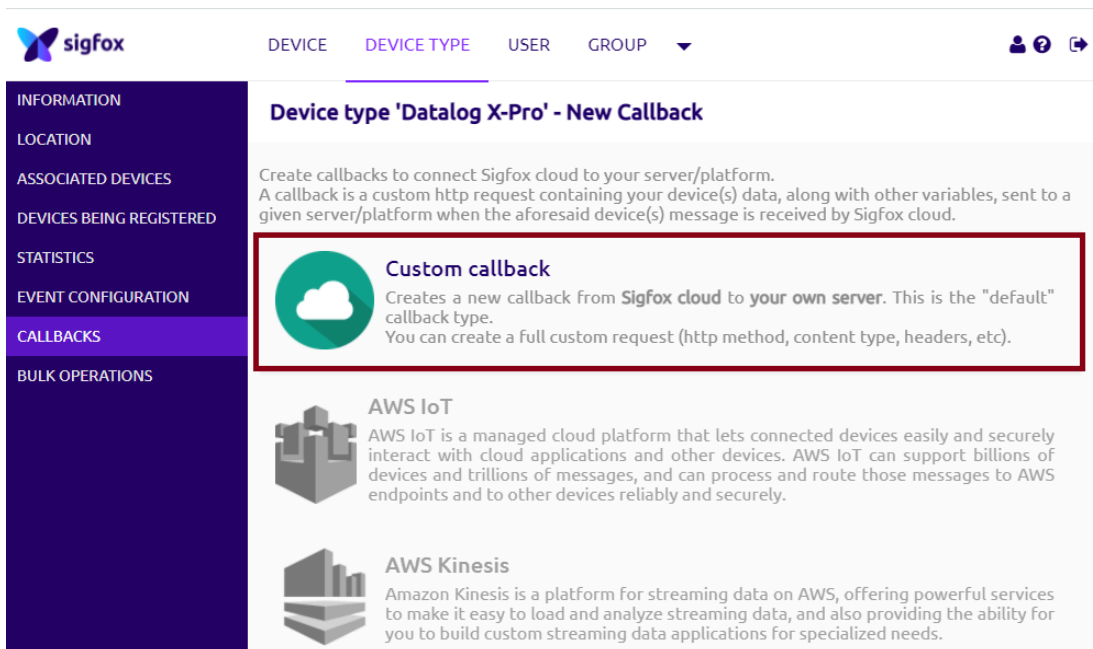

4. Configure the callback as presented in the image below, and then press OK.

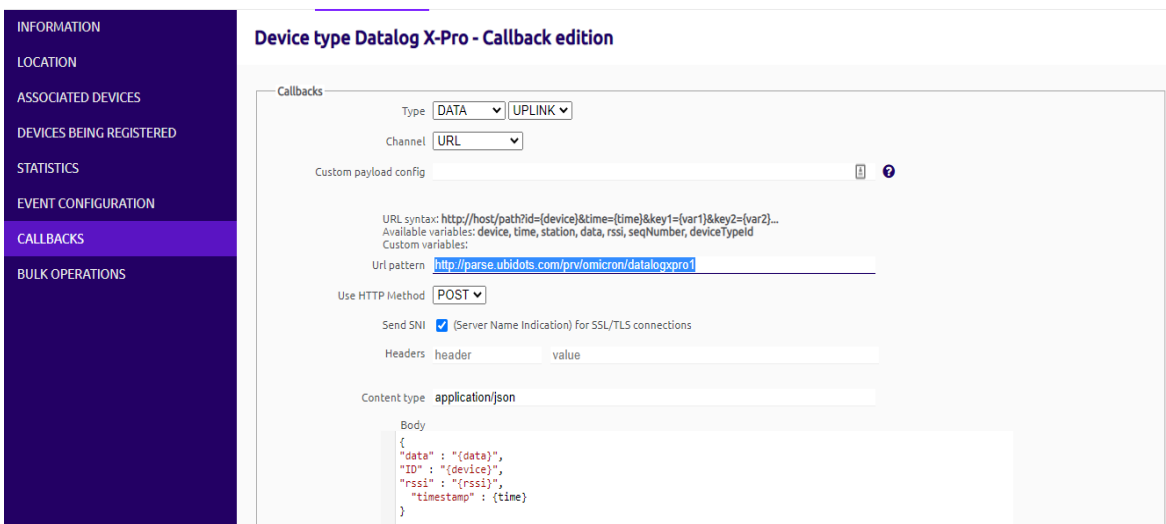

- Use the URL pattern: <http://parse.ubidots.com/prv/omicron/datalogxpro1>
- Use the body:

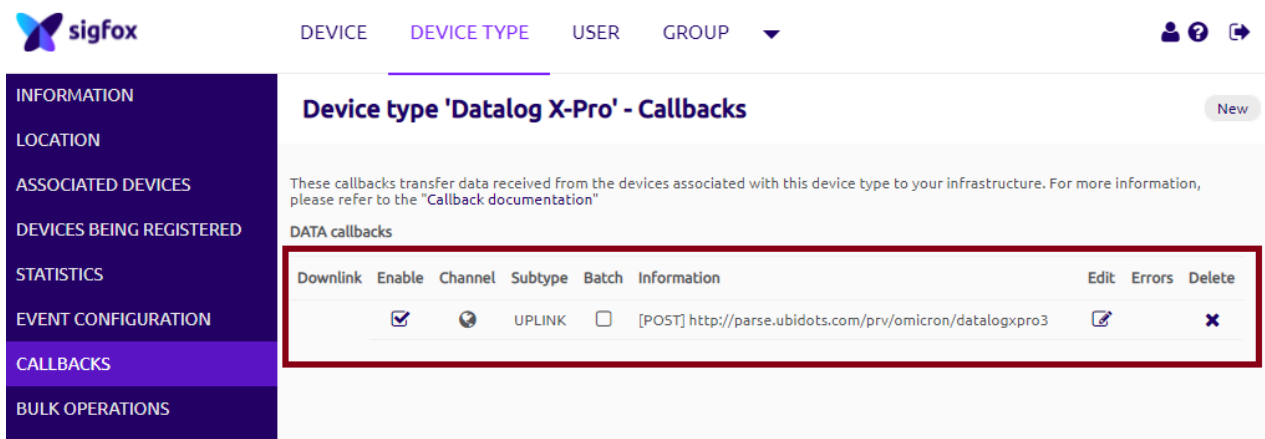

```
{
  "data": "{data}",
  "ID": "{device}",
  "timestamp": {time}
}
```

5. Then, in the Callbacks section of the edited device type, you will see a Callback like the following one:

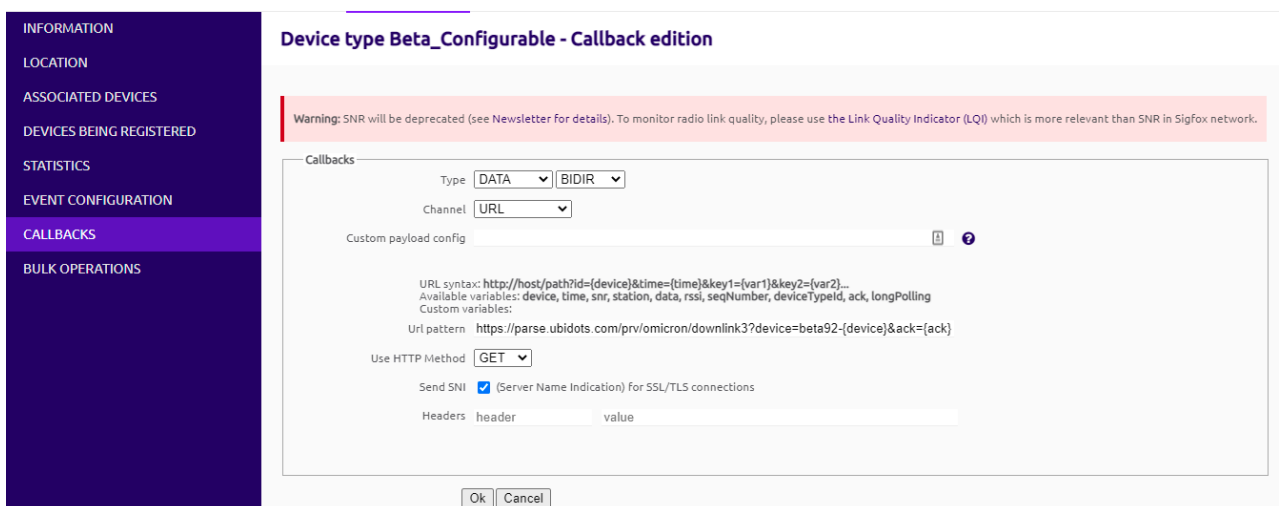

7.2 Callback configuration for Downlink Messages

1. Follow steps 1 to 3 of section 7.1, then, configure the new Custom Callback as the following one, and then press “OK”:



- Type DATA: BIDIR
- Channel: URL
- Use HTTP Method: GET

- Use the URL pattern:

<https://parse.ubidots.com/prv/omicron/downlink3?device=datalogxpro-{device}&ack={ack}>

2. Then, in the Callbacks section of the edited device type, you will see a new Callback of type BIDIR like the following one:

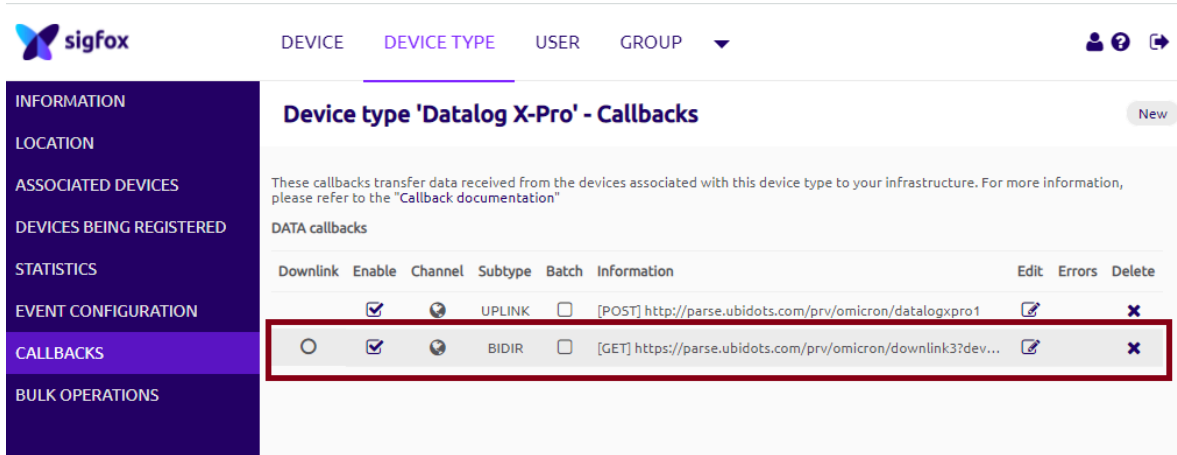

3. You will notice that this Callback is accompanied by an unfilled circle in its Downlink category. This means that the callback has not been manually selected to handle downlink messages of the device type. Before making this selection, check the following:

4. Go to the INFORMATION section of the device type and edit the Downlink Data option to assign it the value CALLBACK. Finally, press "OK".

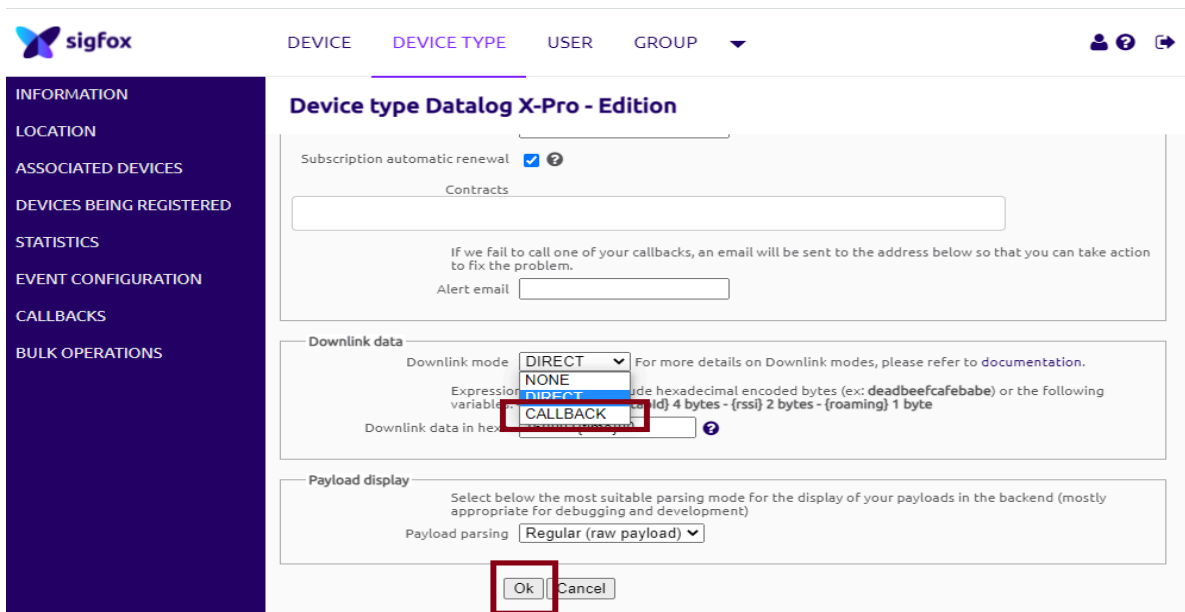
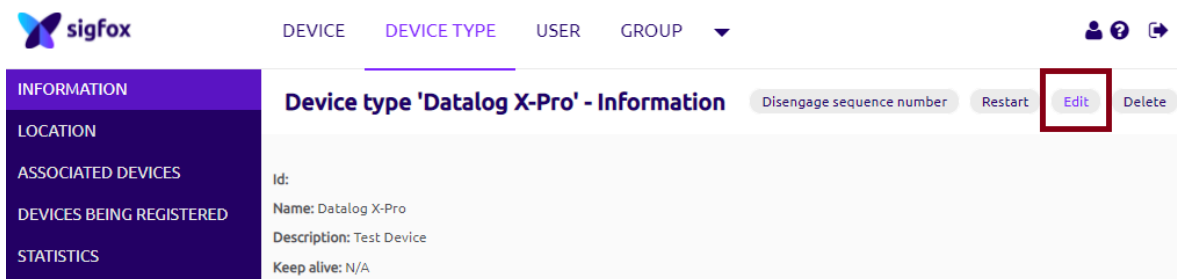

5. Now you can select the new BIDIR callback available as a callback to handle downlink messages in the CALLBACKS section of the edited device type, by clicking on the unfilled circle (after selecting it, the circle will be filled):

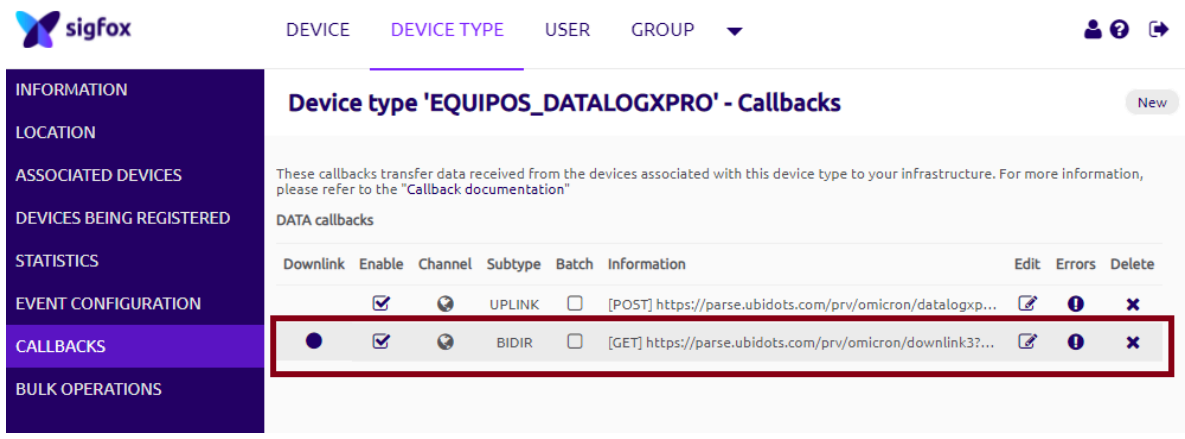

The screenshot shows the Sigfox management interface. On the left is a navigation menu with 'CALLBACKS' selected. The main area is titled 'Device type 'EQUIPOS_DATALOGXPRO' - Callbacks'. Below this is a table of 'DATA callbacks'.

Downlink	Enable	Channel	Subtype	Batch	Information	Edit	Errors	Delete
<input checked="" type="checkbox"/>	<input checked="" type="checkbox"/>		UPLINK	<input type="checkbox"/>	[POST] https://parse.ubidots.com/prv/omicron/datalogx...			
<input type="checkbox"/>	<input checked="" type="checkbox"/>		BIDIR	<input type="checkbox"/>	[GET] https://parse.ubidots.com/prv/omicron/downlink3?...			

Section 8: Configuration on LoRaWAN™ TTN

If it is desired that the **Datalog X-PRO** devices to work with the Omicron IoT Solutions monitoring platform using the LoRaWAN™ Telecommunications Network, the user can allow bidirectional communication with the platform by associating Callbacks to the Uplink and Downlink messages of the devices in the “**The Things Network**” (TTN) platform or other.

NOTE:

For proper operation select the correct LoRaWAN™ module configuration in the **Datalog X-PRO** (see sections 6.2.4 and 6.2.5) depending on the Regional LoRaWAN™ Band.

Datalog X-PRO 2.0 USA

USA, Mexico, Brazil: US915 band

Latin America and Australia: AU915 band

Datalog X-PRO 2.0 EU

Europe: EU868 Band

Uplink-Downlink protocol for third party platforms:

If you want to use another monitoring platform, please don't hesitate to contact us and ask for the **Communication Protocol Manual** for the Datalog X-PRO.

8.1 Callback configuration for LoRaWAN™ Uplink Messages

Follow the next steps:

1. In The Things Network, enter the application to which you have associated the LoRaWAN™ modules used by your **Datalog X-PRO** devices, and select Webhooks, displaying the Integrations menu located on the left side.

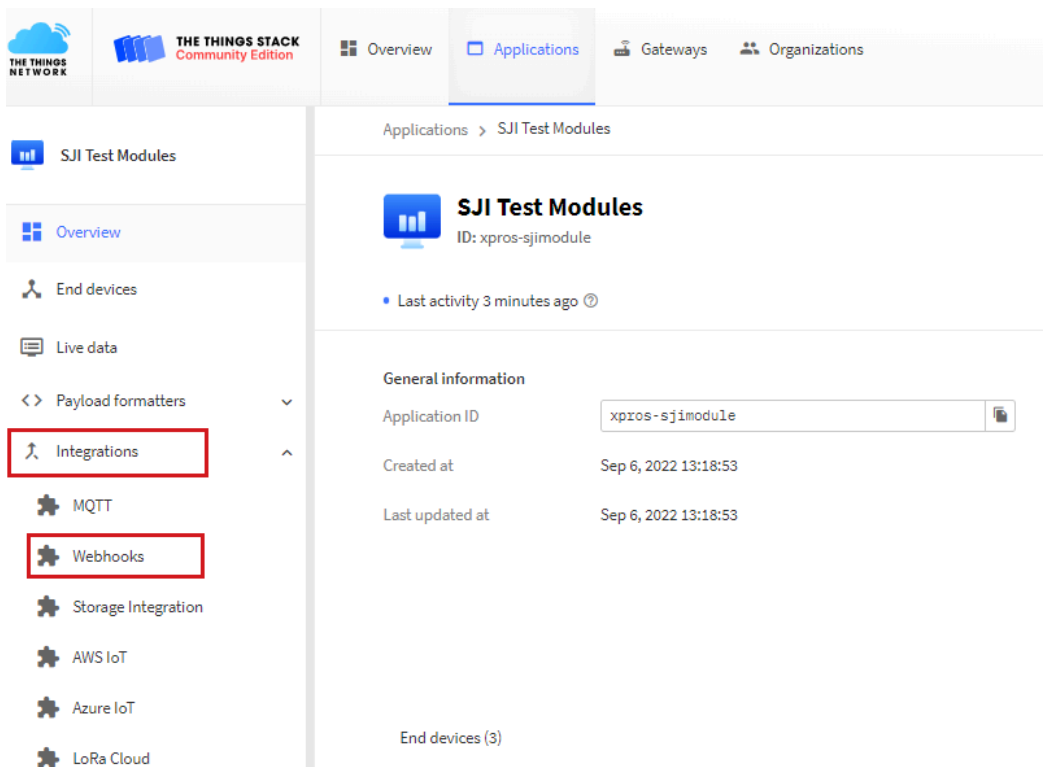

The screenshot shows the TTN web interface. The top navigation bar includes 'Overview', 'Applications', 'Gateways', and 'Organizations'. The 'Applications' menu is active, showing 'SJI Test Modules'. The left sidebar has 'Integrations' selected, with 'Webhooks' highlighted. The main content area shows the application details for 'SJI Test Modules' (ID: xpros-sjimodule), including its creation and last update times.

General information	
Application ID	xpros-sjimodule
Created at	Sep 6, 2022 13:18:53
Last updated at	Sep 6, 2022 13:18:53

End devices (3)

2. Create a new Webhook by selecting the "Add Webhooks" option.

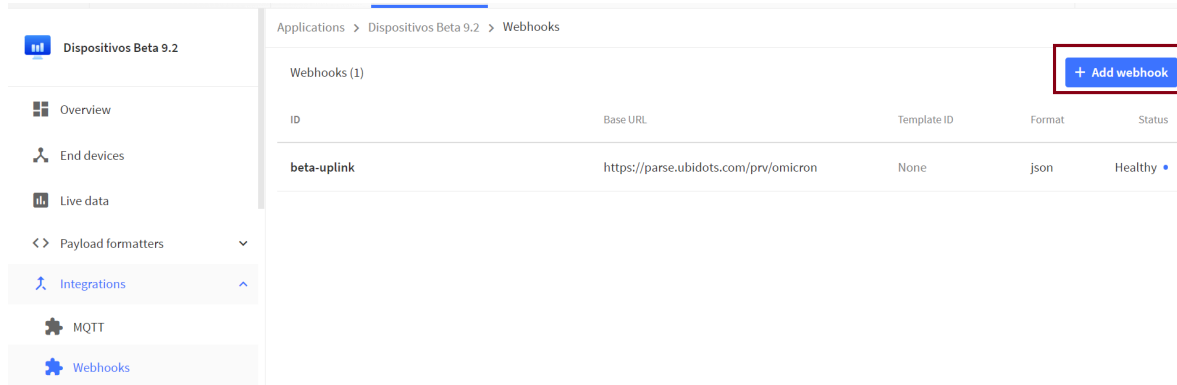

3. Then select "Custom webhook"

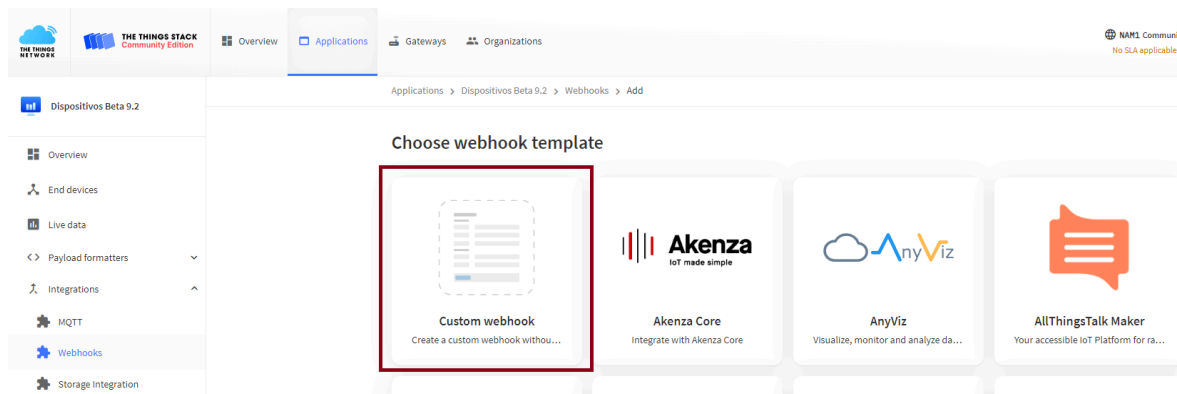

4. Configure the webhook as presented in the following image, and then press "Save changes".

General settings

Webhook ID *

Webhook format *

Base URL *

Downlink API key

The API key will be provided to the endpoint using the "X-Downlink-Apikey" header

Request authentication ?

Use basic access authentication (basic auth)

Additional headers

+ Add header entry

Filter event data ?

+ Add filter path

Enabled event types

For each enabled event type an optional path can be defined which will be appended to the base URL

Uplink message

An uplink message is received by the application

- **Webhook ID:** ID that the user wants to assign
- **Webhook format:** JSON
- **Base URL:** Base URL chosen by the user. In the case of the Omicron IoT Solutions monitoring platform: <https://parse.ubidots.com/prv/omicron>
- **Downlink API key:** See section 8.1.1.
- **Uplink message:** Enable and add the path: [/uplink-lora-xpros-generico](#)

5. Then, in the webhooks section, you will be able to see the following:

Webhooks (1) + Add webhook				
ID ↕	Base URL ↕	Template ID ↕	Status	Created at ↕
xpro2-sji-ubidots	https://parse.ubidots.com/prv/omicron	None	Healthy •	Sep 8, 2022

8.1.1 Downlink API key

To obtain this parameter, follow the steps below.

1. In TTN, go to the application to which you have associated the LoRaWAN™ modules used by your **Datalog X-PRO** devices and select “API Keys”.

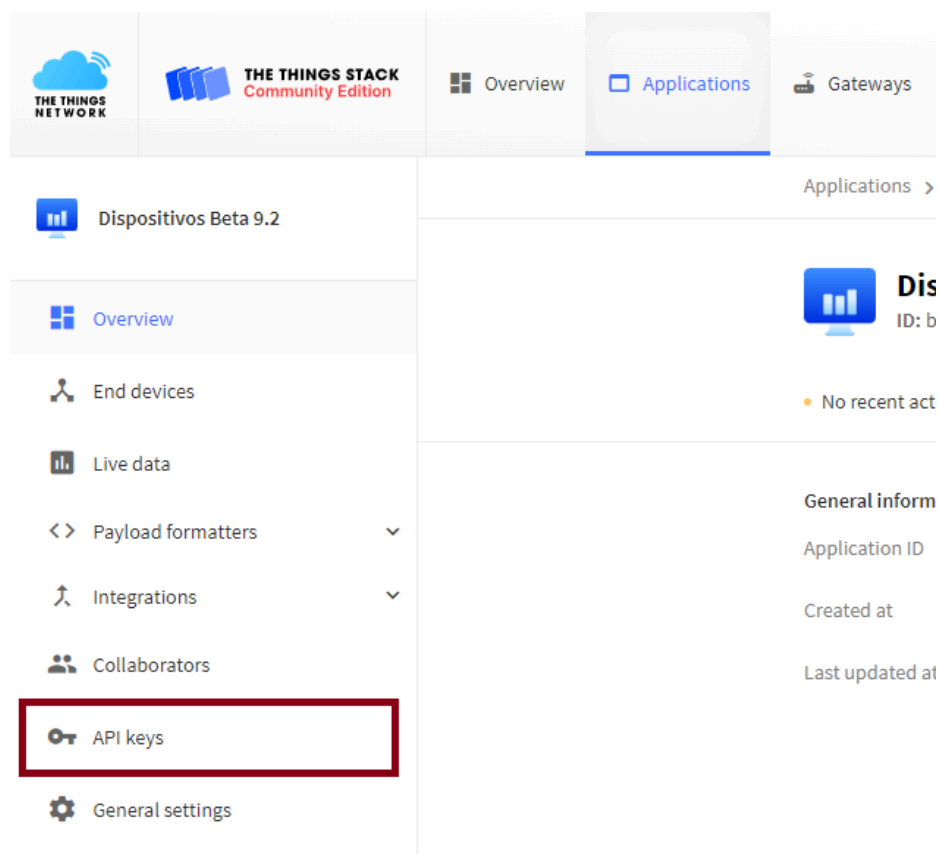

The screenshot shows the 'Applications' page in The Things Stack. The left sidebar contains a menu with the following items: Overview, End devices, Live data, Payload formatters, Integrations, Collaborators, **API keys** (highlighted with a red box), and General settings. The main content area shows the application details for 'Dispositivos Beta 9.2', including a 'Dis' ID and a 'No recent act' status.

2. Select the option “Add API Key”.

Applications > Dispositivos Beta 9.2 > API keys

API keys (1) + Add API key

Key ID	Name	Granted Rights
HFN3Y0IINLNX5JKUP3MSR3J76TLGRWG UW7K...	downlink-key	Application Link Application Traffic Read

3. Configure the webhook as presented in the following image and then press “Create API key”.

Add API key

Name

Rights *

Grant all current and future rights

Grant individual rights

Select all

Delete application

View devices in application

View device keys in application

Create devices in application

Edit device keys in application

View application information

Link as Application to a Network Server for traffic exchange, i.e. read uplink and write downlink

This implicitly includes the rights to view application information, read application traffic and write downlinks

View and edit application API keys

Edit basic application settings

View and edit application collaborators

View and edit application packages and associations

Write downlink application traffic

Read application traffic (uplink and downlink)

Write uplink application traffic

Create API key

4. The following window will appear, copy the key because after closing, it will never be shown again, and press “I have copied the key”.

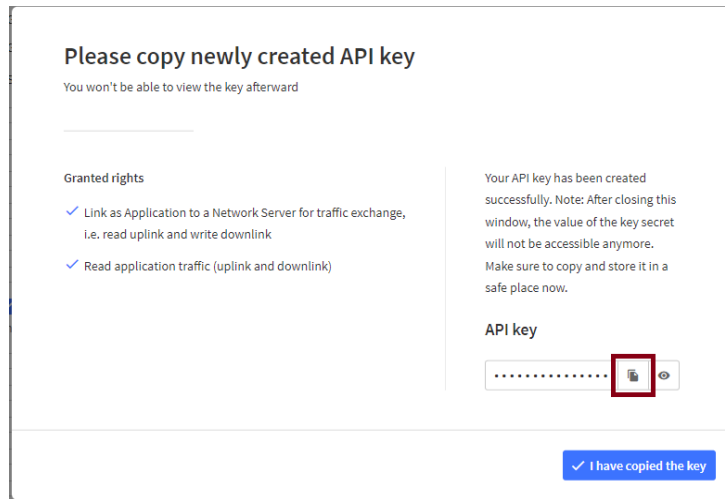

5. Then edit and copy this API key in your **Webhook: "Downlink API Key"**

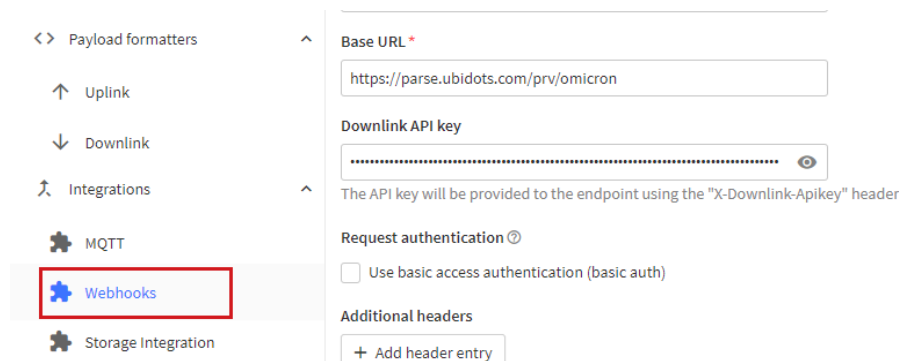

8.2 Format for Uplink payload

1. In The Things Network, enter the application to which you have associated the LoRaWAN™ modules used by your Datalog X-PRO devices, and select "Uplink", displaying the Payload Formatters menu located on the left side.

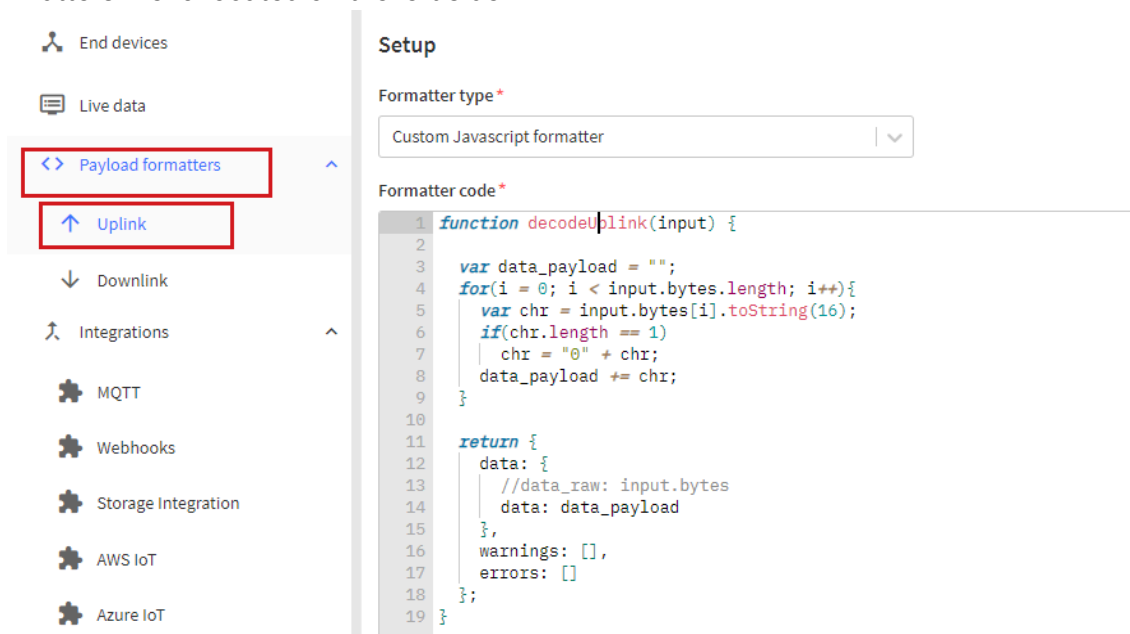

2. Then, enter the following information in the corresponding fields:

- **Formatter type:** Custom Javascript formatter
- **Formatter code:** Copy and paste the next function code:

```
function decodeUplink(input) {  
  
    var data_payload = "";  
    for(i = 0; i < input.bytes.length; i++){  
        var chr = input.bytes[i].toString(16);  
        if(chr.length == 1)  
            chr = "0" + chr;  
        data_payload += chr;  
    }  
  
    return {  
        data: {  
            //data_raw: input.bytes  
            data: data_payload  
        },  
        warnings: [],  
        errors: []  
    };  
}
```

Section 9: Centriomega® Remote Control and Monitoring Platform

The Datalog X-PRO works in conjunction with the Remote Monitoring WEB platform.

Users can access the Remote Monitoring Platform via WEB, to perform, among other things:

- Remote monitoring and visualization of historical data records, in graphs and data tables, for up to 2 years.
- Alarm management for variables out of range, battery levels, and main power supply failure.
- Add comments to alarm records.
- Set alarm limits, among other custom settings, like sensors' names.
- Configure alarm events, such as external notifications by email, SMS, voicemail, Telegram messaging service or via webhooks.

9.1 Access the Centriomega® Remote Monitoring Platform

Using the credentials provided by the manufacturer, the device's user can log in at iot.omicroning.co



Figure 9-1 Access to the Remote Monitoring Platform

NOTE:

If you don't have the login credentials, please contact the supplier or manufacturer of the device. **Remember that you can find the contact information at the beginning of this document.**

The platform uses some basic elements to organize the information it manages and facilitate interaction with users. These are: **Dashboards, Devices, and Events**.

An introduction to the use of each of them will be offered in this guide.

9.2 Reviewing Historical Data

Dashboards are interfaces where relevant data is presented to the users. The referred platform allows to edit or create custom Dashboards to integrate any information desired (if using an account with permission to do so); however, by default, it offers panels for remote monitoring of the data published by all the devices linked to the platform, and panels to display Alarms or Events that have recently occurred.

To review a Dashboard, initially follow what is indicated in Section 9.1, to access the platform.

Inside the platform, users can find a link to the section that includes all the Dashboards available to their accounts. There, they can select the Dashboard of their interest:

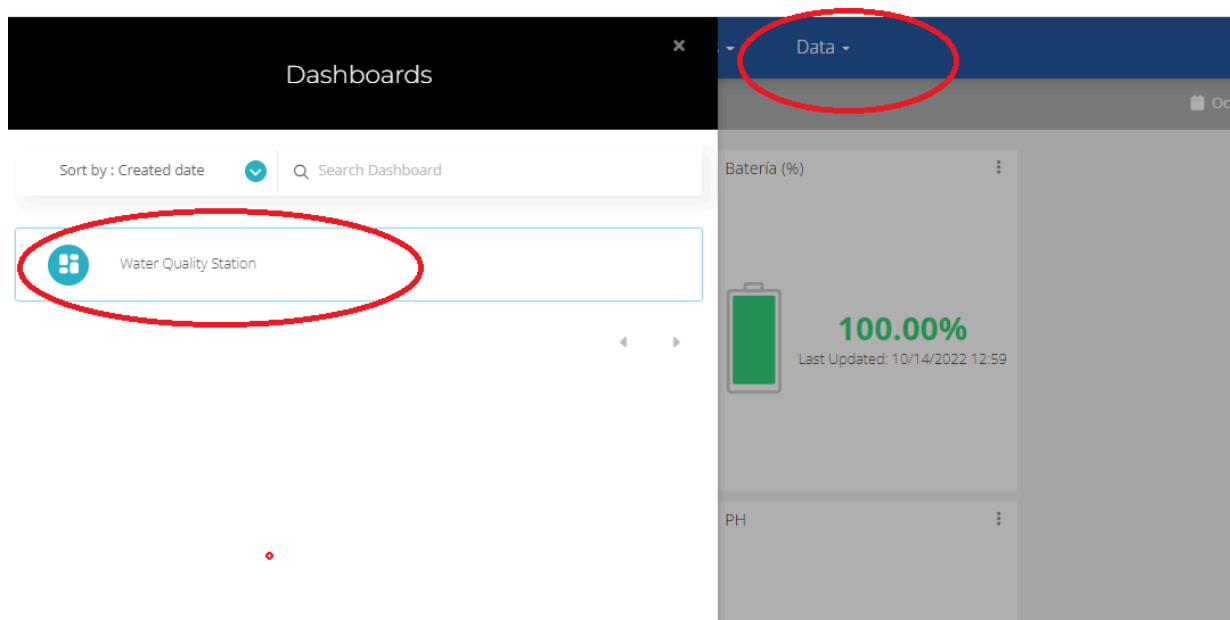

Figure 9-2 Dashboard selection

After selecting a particular Dashboard, users are able to see the information that corresponds to that panel in multiple graphs and visual elements:



Figure 9-3 Dashboard visualization example

To learn how to modify said elements and how to configure a Dashboard, **you can contact the manufacturer of the Datalog X-PRO**. Remember that Contact Information is provided at the beginning of this document.

9.3 Reviewing Devices, their Variables, and Configuration

A Device is a virtual representation of a physical device that takes data from sensors and transmits them through a particular network to the platform. Thus, each Device visible to an account receives the data of the physical equipment acquired by the administrator of the account.

The data received by a device is stored and organized in multiple variables.

To review a specific Device, initially follow what is indicated in Section 9.1, to access the platform.

Inside the platform, users can find a link to the section that includes all the available Devices to their accounts and select the Device of their interest:

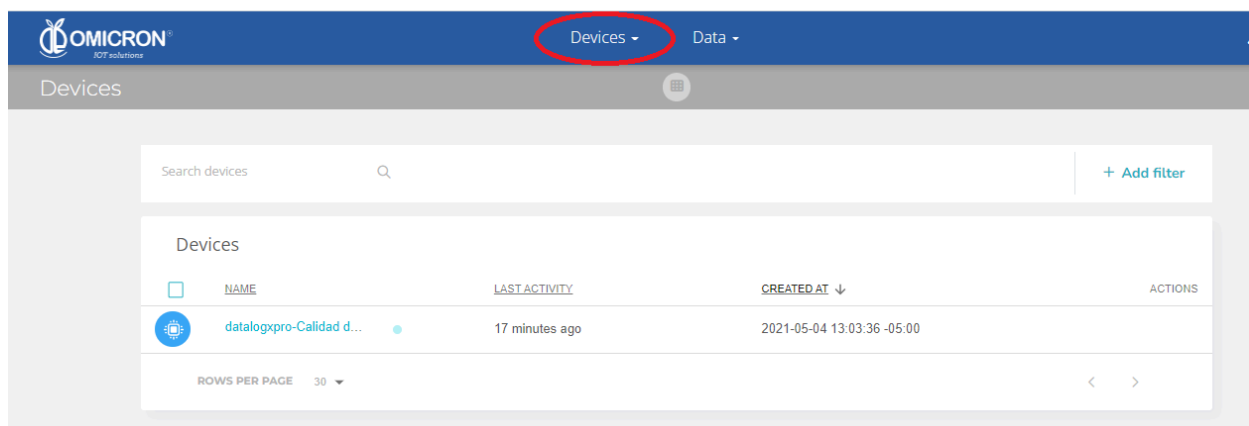

Figure 9-4 Device selection page

After selecting a particular Device, the user is able to see the information that corresponds to that Device in multiple panels and Variables.

Reviewing the Variables of a certain Device allows for checking the update status and the current measure of each Variable. If it is suspected that one variable is not being updated properly, after entering the Device panel that should include it, its last activity period could be reviewed.

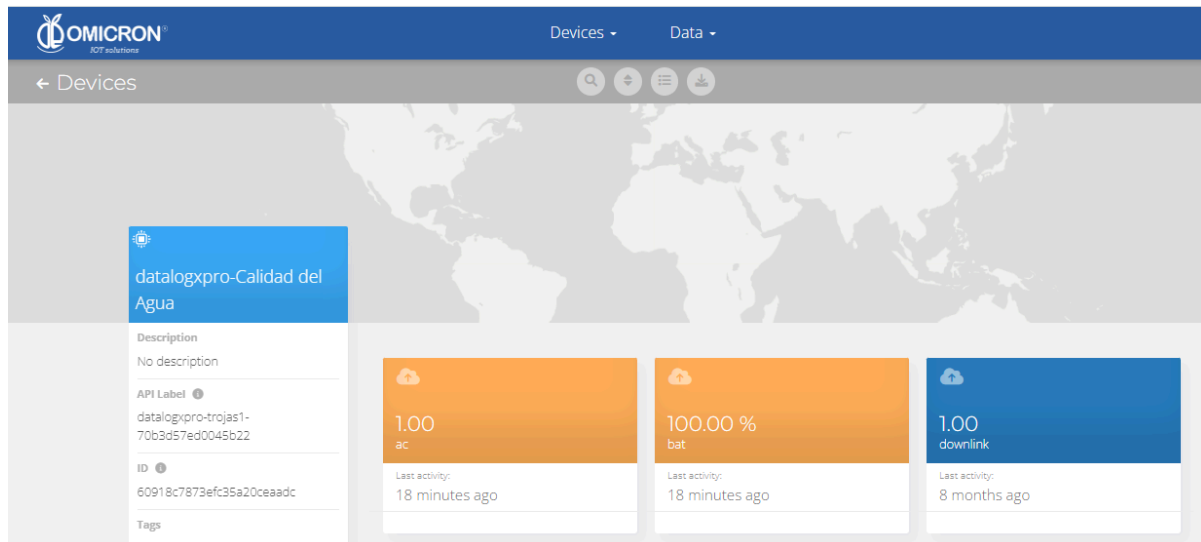

Figure 9-5 Reviewing the Variables of a Device

To review the historical data of a certain Variable, in a Device, select the Variable.

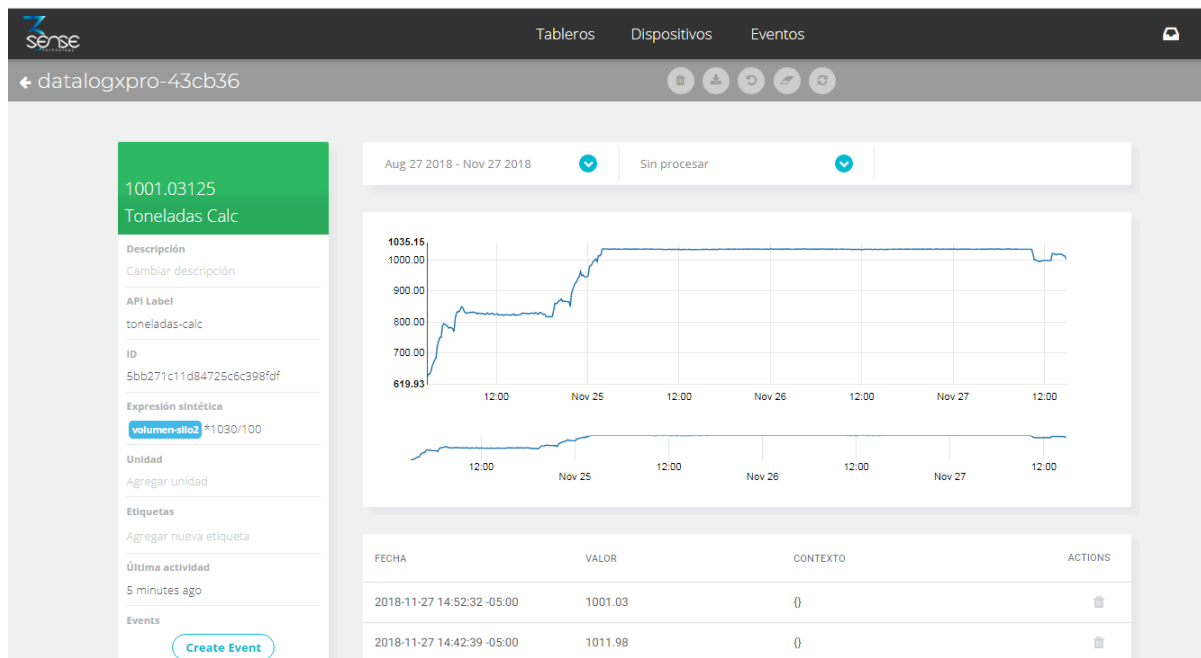

Figure 9-6 Variable Historical Data

9.4 Reviewing Alarms and Programmed Events

Events (or Incidents) are configurable conditions that activate the sending of alert messages via email, SMS, Telegram, or Webhooks. Violated conditions, which may have been responsible for sending messages to users, can be reviewed in a Dashboard associated with your account, in whose name the suffix -Alarms is included.

To review an Event, initially follow what is indicated in Section 9.1, to access the platform.

Inside the platform, users can find a link to the section that includes all the Events available to their accounts and locate the Event of their interest:

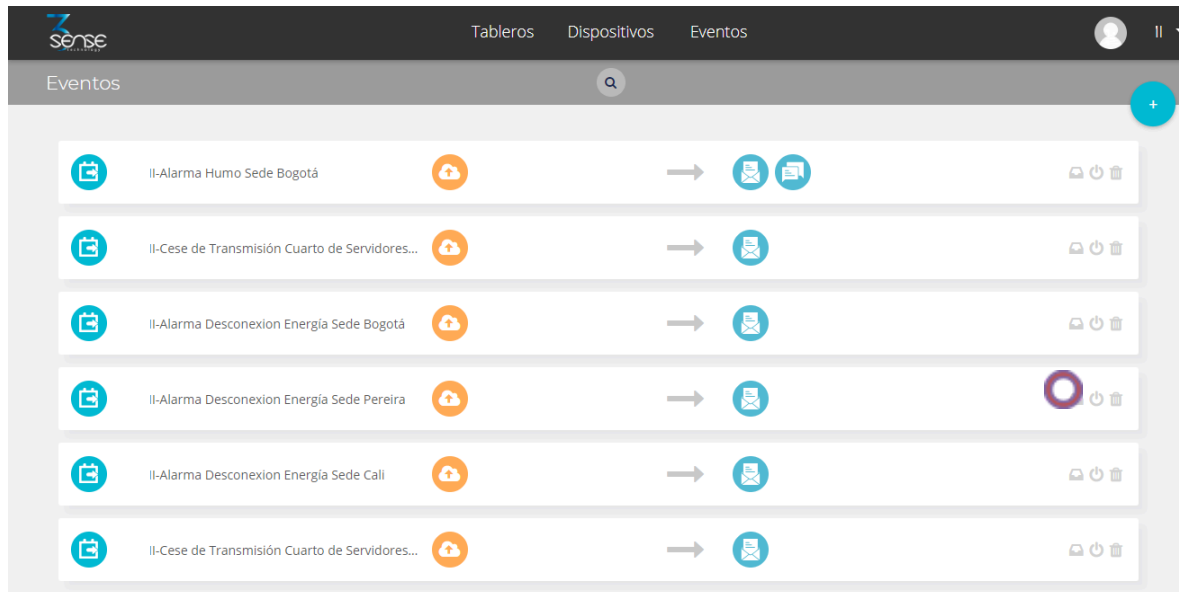

Figure 9-7 Events Configuration

To review the last activity of an Event (its log of updates, or the times in which one of its conditions where violated), the user can press the Log icon associated to any Event to see a table like the following one:

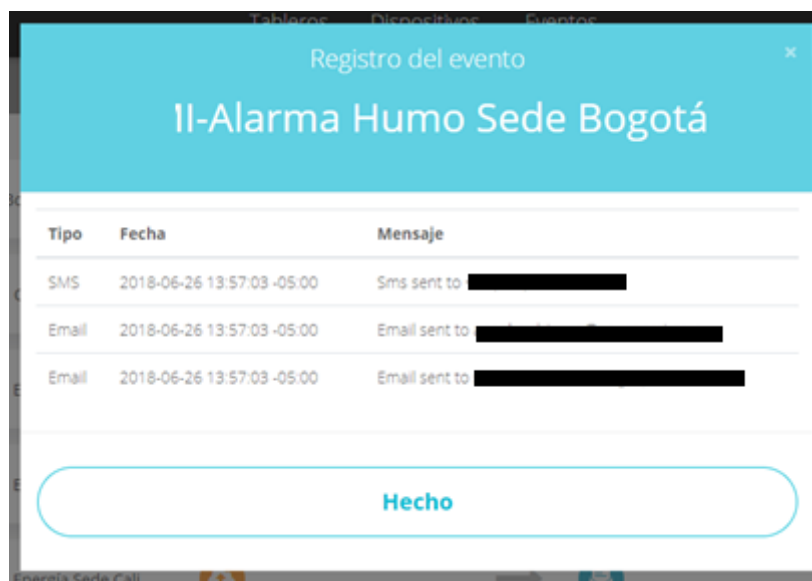

Figure 9-8 Events historical record

To review the Dashboard with the recently activated Alarms, refer to section 9.2, and look for the Dashboard whose name contains the suffix -Alarms.

This Dashboard will contain a table like the following one:

Incidentes							
Dispositivo	Variable	Activado	Reconocido	Resuelto	Mensaje	Comentarios	
	II-Sede Medellin		Agosto 02 2018 - 08:55:06	-	-	II-ALARMA Temperatura Sede Medellin	Ver comentarios
	II-Sede Medellin		Agosto 01 2018 - 15:27:40	-	Agosto 01 2018 - 15:30:42	II-ALARMA Temperatura Sede Medellin	Ver comentarios
	II-Sede Medellin		Agosto 01 2018 - 11:00:28	-	Agosto 01 2018 - 15:26:42	II-ALARMA Temperatura Sede Medellin	Ver comentarios
	II-Sede Medellin		Julio 31 2018 - 12:04:02	-	Agosto 01 2018 - 10:47:27	II-ALARMA Temperatura Sede Medellin	Ver comentarios
	II-Sede Medellin		Junio 05 2018 - 01:36:58	-	Julio 31 2018 - 11:31:16	II-ALARMA Temperatura Sede Medellin	Ver comentarios
	II-Sede Medellin		Mayo 25 2018 - 11:57:34	-	Junio 05 2018 - 01:35:47	II-ALARMA Temperatura Sede Medellin	Ver comentarios
	II-Sede Medellin		Mayo 25 2018 -	-	Mayo 25 2018 -	II-ALARMA Temperatura Sede	Ver comentarios

Figure 9-9 Events Dashboard

To learn how to modify the configuration of an Event, **you can contact the manufacturer of the Datalog X-PRO**. Remember that Contact Information is provided at the beginning of this document.

9.5 Remote Configurator

Centriomega® platform users have access to a Dashboard that allows them to set commands to remotely configure their devices (to find it, login to the remote monitoring platform following the steps described in Section 9.1, and look for the Dashboard with the name "Remote Configurator", following the steps described in Section 9.2).

The "Remote Configurator" Dashboard presents to the users a summary of the configuration options available for each type of the Omicron IoT solutions devices, and only requires them to choose a parameter to configure, after indicating the device model, and the elements or general aspects of the device to be configured. The elements it contains are:

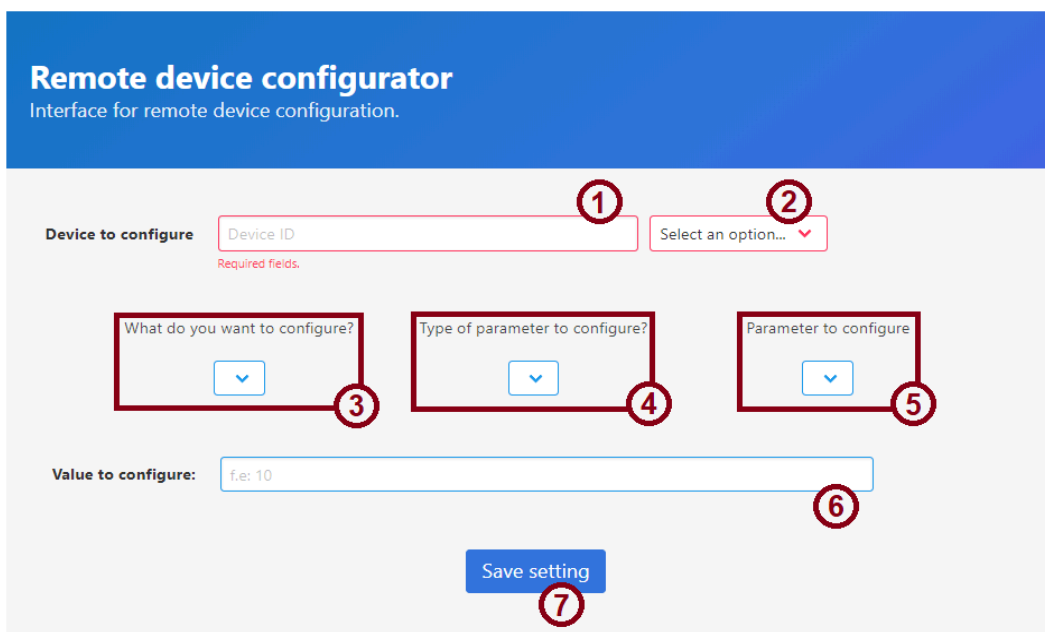

Remote device configurator
Interface for remote device configuration.

Device to configure: 1 2
Required fields.

What do you want to configure? 3 4 5

Value to configure: 6

7

Figure 9-10 Elements of the Remote Configurator

9.5.1 Elements of the Remote Configurator

1. Field for the ID of the device to be configured

In this field, users must specify the ID of the device they wish to configure remotely. This ID is printed on the labels of the devices; or it can be checked in the Device information stored by the platform (to do this, refer to section 10.5).

2. Device type selector to be configured

Allows you to select the model of the device to be configured.

3. General aspect selector to be configured

Here you must select the general aspect of the device to be configured.

4. Parameter type selector to be configured

This list allows you to specify the type of parameter to be configured for the general aspect of the device, chosen with selector 3.

5. Parameter to be configured selector

Finally, this list shows the parameters available for configuration, as chosen in lists 3 and 4.

6. Field for the value to be configured

In this field the user must specify the desired value for the parameter to be configured, following the instructions that the interface presents as a text over this field when the cursor is placed there.

7. Save command button

Once the user has chosen the parameter to be configured, and has specified a configuration value, the user must save the command in the platform so that the device will download it once it is ready to do so.

9.5.2 Use of the interface for remote configuration

To configure a parameter using the Remote Configurator, follow the steps below:

1. Enter the identification information of the device to be configured in fields 1 and 2.
2. Select the parameter to be configured using selection lists 3, 4, and 5.
3. Enter the value you wish to assign to the configured parameter in field 6, **following the indications that the interface presents** as a text on this field, after choosing the parameter to be configured.
4. Having selected the parameter to be configured, and having entered the value with which you wish to configure it, **press the 'Save Setting' button**. You will then be prompted to confirm the action on a pop-up window; and in the case that the configuration is successfully saved, the page will display a message indicating this below the button.

Pressing the button will not clear the entered or selected information, in order to facilitate configuring another device in the same way.

Based on the above, it can be concluded that in the case of selecting and entering in the Remote Configurator, for what is shown in the following image (as an example), the Datalog

X-PRO 4a123b device will set the publishing time (TPU) of its sensor interface 2, to 10 minutes:

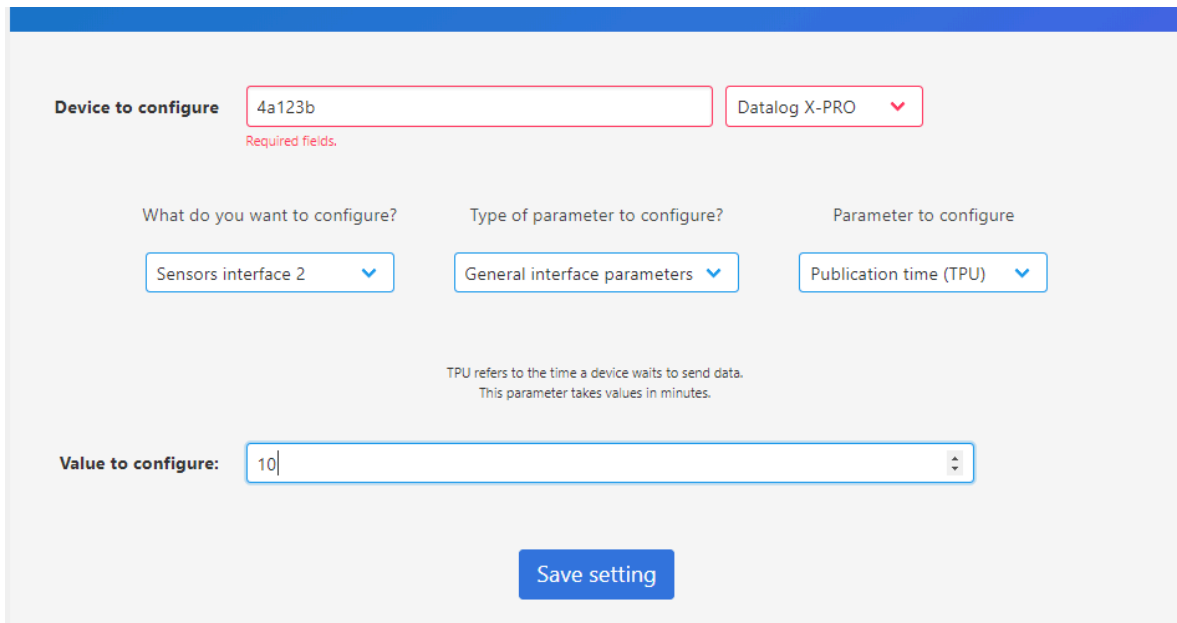

The screenshot shows a configuration interface for a device. At the top, there is a header bar. Below it, the 'Device to configure' section contains a text input field with '4a123b' and a dropdown menu with 'Datalog X-PRO'. A red 'Required fields.' message is visible below the device ID field. The main configuration area has three dropdown menus: 'What do you want to configure?' set to 'Sensors interface 2', 'Type of parameter to configure?' set to 'General interface parameters', and 'Parameter to configure' set to 'Publication time (TPU)'. Below these is a text input field for 'Value to configure:' containing the number '10'. A blue 'Save setting' button is at the bottom. A note states: 'TPU refers to the time a device waits to send data. This parameter takes values in minutes.'

Figure 9-11 Example of the configuration made with the Remote Configurator

Section 10: Troubleshooting Guide

10.1 I cannot access the remote monitoring platform

To access the remote monitoring platform, **use the credentials given by the manufacturer exactly as they were delivered**; that is, if you were assigned a username or password with capitalized characters: you must enter them as assigned.

If you verify that the username or password provided by the manufacturer does not allow you to log in, ask the manufacturer to change them.

10.2 The device has stopped updating data on the monitoring platform

If the monitoring platform does not record recent measurements from the device, perform the following to try to identify the problem:

1. Verify that the device is in the normal operating state:

The normal operating state of a **Datalog X-PRO** can be recognized by checking the LED on the Main Unit cover; if it flashes blue sporadically (about, once per minute), the device indicates being in the normal operating state. Also, in the normal operating mode, whenever a magnet is placed near the Main Unit, as described in Figure 6-1, the LED indicator will light red.

NOTE:

To gain familiarity with the processes signaled by the LED indicator, refer to Section 6 of the manual.

If the LED indicator does not light or flash as described, even when the magnet is brought close as in **Figure 6-1**, it can be assumed that the device is discharged and turned off. Use your AC adapter, or a 12 to 24 V solar panel to recharge it.

NOTE:

Refer to Section 4 of the manual for details on the electrical connection procedures and power requirements for the AC adapter and the solar panel.

2. In the normal operating state, force the device to send data:

To perform this step, **it is first indispensable to ensure that the device is within the coverage area of the wireless network**, so try to place it in a location that does not obstruct its wireless transmissions (away from metal surfaces or objects, and from sturdy objects such as walls or shelves; and preferably, located in a high place).

Next, briefly move the magnet (for 1 second) 2 times close to the Datalog X-PRO, as shown in Figure 6-1. **The main LED will indicate that the magnet has been approached correctly by lighting red as long as it is close to the device.**

After briefly approaching the magnet 2 times, the main LED of the device will flash blue to show that it is reading its peripherals, and then it will flash green or yellow-green to indicate that it is sending information, where the number of flashes will depend on the configured zone and communication protocol (See Table 6-2). If this does not occur, try the operation again.

NOTE:

Remember that while the device is busy executing an action, **the LED Indicator will remain on until the device finishes executing that action**. Therefore, if the device does not respond to the magnet, please wait until you notice that there is no LED activity for more than 10 seconds.

If after performing the action that forces the device to send data, it still does not update data on the platform, follow the tips described below.

10.3 After forcing the device to send data, I cannot see the updates on the platform

If after forcing the device to send data (which can be verified by checking the behavior of its main LED and verifying that it corresponds to what is described in Section 10.2), you still cannot see the updates on your Dashboard, do the following:

NOTE:

Remember that while the device is busy executing an action, **the LED Indicator will remain on until the device finishes executing that action**. Therefore, if the device does not respond to the magnet, please wait until you notice that there is no LED activity for more than 10 seconds.

1. If it transmits data through the Sigfox network, verify that the device is configured for the appropriate Sigfox zone:

The **Datalog X-PRO 2.0 USA** devices can be configured to connect to Sigfox networks in two zones. If a device is configured in a zone that does not correspond to the geographic location of the device, the device will not send data.

The zones that correspond to the different territories in which Sigfox operates are:

European Union: Sigfox Zone 1 (**Datalog X-PRO 2.0 EU** Model).

United States, Mexico, Brazil: Sigfox Zone 2 (**Datalog X-PRO 2.0 USA** Model).

Latin America and Australia: Sigfox Zone 4 (**Datalog X-PRO 2.0 USA** Model).

To change the zone configuration of the **Datalog X-PRO 2.0 USA** device, **briefly approach a magnet to the Datalog X-PRO 10 times**, as shown in Figure 6-1; after this, its main LED will respond by flashing purple several times; and then, it will remain green with a few intermittent flashes (to indicate that it is configuring the communications module). If it flashes purple 2 times (and then green), the device has been configured to operate in Zone 2; on the other hand, if it flashes purple 4 times (and then green), the device has been configured to operate in Zone 4.

2. If it transmits data over the LoRaWAN™ network, verify that the device is configured for the appropriate Regional Band:

The **Datalog X-PRO 2.0 USA** devices can be configured to connect to the LoRaWAN™ networks in two different Regional Bands. If a device is configured in a Regional Band that does not correspond to the device's geographic location, the device will not send data.

The Regional Bands that correspond to the different territories in which LoRaWAN™ operates are:

European Union: LoRaWAN™ EU868 (**Datalog X-PRO 2.0 EU Model**).

United States, Mexico, Brazil: LoRaWAN™ US915 (**Datalog X-PRO 2.0 USA Model**).

Latin America and Australia: LoRaWAN™ AU915 (**Datalog X-PRO 2.0 USA Model**).

To change the zone settings of the **Datalog X-PRO 2.0 USA device**, briefly approach a magnet to the **Datalog X-PRO 10 times**, as shown in Figure 6-1; after this, its main LED will respond by flashing purple several times; and then, it will remain green with a few intermittent flashes (to indicate that it is configuring the communications module). If it flashes purple 2 times (and then green), the device has been configured to operate in the LoRaWAN™ US915 Regional Band; on the other hand, if it flashes purple 4 times (and then green), the device has been configured to operate in the LoRaWAN™ AU915 Regional Band.

3. Contact the manufacturer

If after verifying that the problem with your device cannot be corrected by following the recommendations given in the previous points, contact the manufacturer. Remember that contact information is provided at the beginning of this document.

10.4 When trying to save the configuration with the Remote Configurator, I see the message, "You do not have permission to perform this configuration. It is recommended to check the device ID entered, or the type of device selected."

The interface does not allow you to configure devices that do not exist, or to which you do not have access from your account; therefore, the message will appear if you enter the ID of a device not associated with your account, or if you select a device type that does not correspond to the one of the ID entered. It is recommended that you check the ID and type of the device you intend to configure before attempting to configure it. If you receive the message, even if you enter the correct device ID information, request assistance from Omicron IoT Solutions technical staff. Remember that contact information is provided at the beginning of this document.

10.5 I can't see the device ID on its label

Each device is delivered with a label on its back where you can find the ID, or MAC fields (these are different from the FCC ID, which you should ignore). However, if you are unable to locate the ID information on a device label, you can review the ID information of the devices associated with your account on the remote monitoring platform. To do this, after logging into the platform, in the 'Devices' tab, select the 'Devices' option (1, in Figure 10-1); then, in the list that appears, find and select the device for which you want to know the identification information (2, in Figure 10-1); and finally, locate the ID in the "API Label" field on the page with the device information (3, in Figure 10-1).

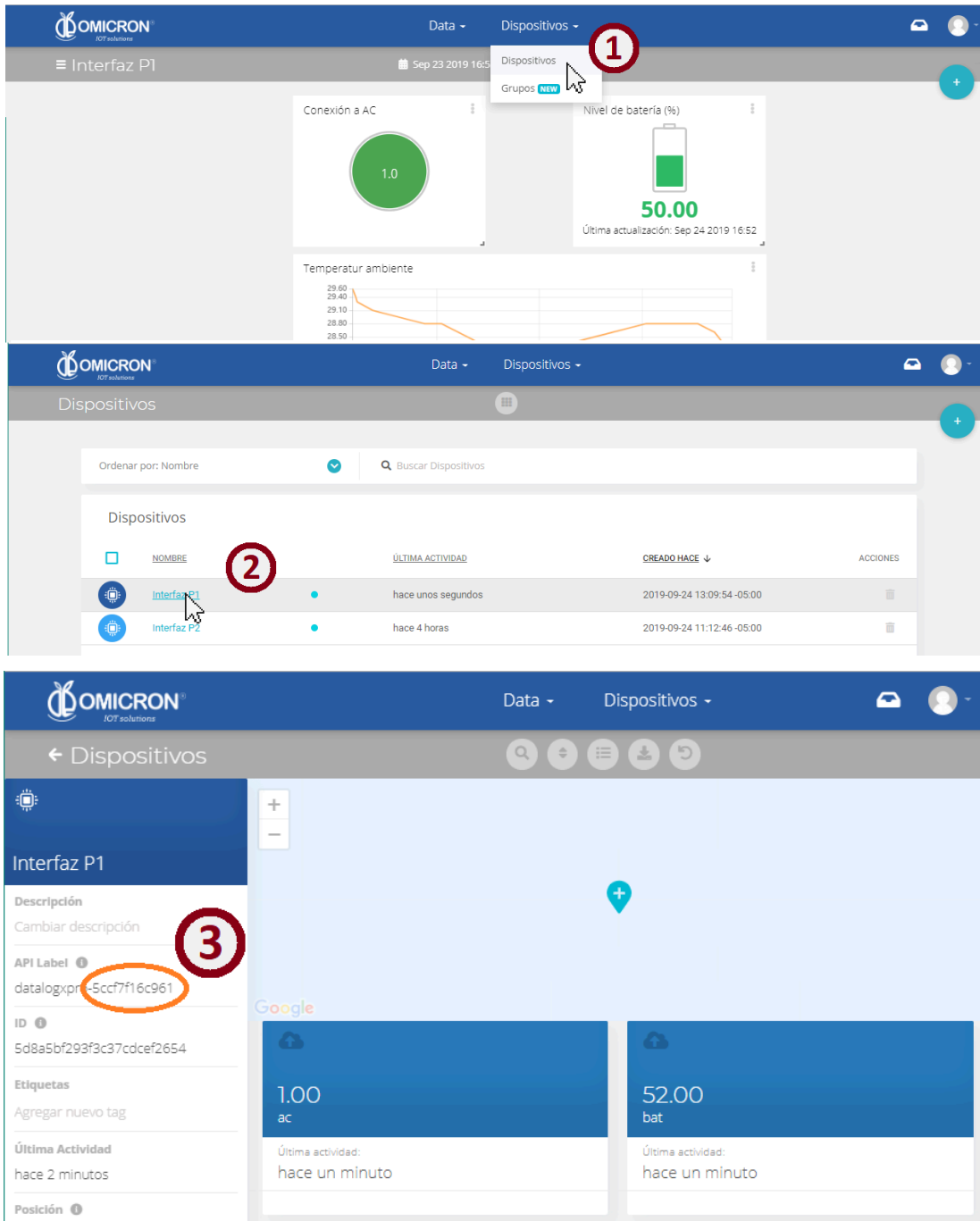

Figure 10-1 Device ID search on the remote monitoring platform

The API Label of each device is composed of its type, and its ID, separated by a hyphen (e.g. datalogxpr-123abc). Once you have identified the ID of interest, you can use it to specify the device to be configured with the Remote Configurator.

⚠ CAUTION

Do not modify the "API Label" of a device associated with your account for any reason.



Appendix A: Specifications and Reference Data

A.1 Specifications

A.1.1 Performance specifications

Recommended Environmental conditions:

- Altitude: up to 2600 m.
- Ambient Temperature: 5°C to 40 °C (41°F – 104°F).
- Maximum Relative Humidity: 100%

A.1.2 Functional specifications

General Features:

- Ports for three sensors.
- Sigfox / LoRaWAN™ wireless transmission module.
- Rechargeable Li-Ion battery.

Visualization

Web/App interface for visualization of:

- Current sensed measures.
- Alarm limits configuration, among other parameters.
- Graphic record of each variable for up to 2 years.

Alarms

- Remotely display alarms on WEB or mobile applications.
- External alarms by SMS, e-mail, and Telegram messaging service, or Webhooks.

Field of application

Industrial, Precision Agriculture, Early warning systems, Health, Smart Cities.

A.1.3 Power supply

Supply voltage: 12 – 24 V DC

Power Rating with sensors: Max. 6W @ 12VDC.

Maximal Current of the Device without Sensors: 130mA in Tx Mode and Charging the Internal Battery

Standby Current: 8mA. The device reads sensors every minute and enters Sleep mode.

Average Power Consumption (No sensors and fully recharged battery): 0.12 W @ 12 V DC.

BATTERY

Model: DTP563567 1500mAh 3.7V

Manufacturer: DATAPOWER

Type: Li-Ion

IEC 62133-2 certificate.

Voltage and Maximum current supplied for all sensors in the Output Ports:

- 10.3 V /0.5A For Input Power Supply 12V/0.7A
- 12.0 V/ 0.5A For Input Power Supply 14V/0.6A
- 12.0 V/ 0.5A For Input Power Supply 24V/0.3A

AC/DC Adapter (Only for Indoor use):

- **Model:** TRE15120E 12V/ 1A
- **Manufacturer:** CINCON
- **Input:** 100 ~ 240 VAC, 47 ~ 63Hz, 0.5A - 100VAC
- **Rated Output:** 12V±2.0%, 1A.
- **Power Rating:** Max. 12W @ 12VDC.
- Approved IEC/EN/UL 62368-1
- Meets EN55032 Class B and CISPR/FCC Class B

A.1.4 Communication

Datalog X-PRO 2.0 USA

- **Module:** SJI LSM110A.
- **Manufacturer:** SEONGJI
- **Sigfox dual zone:** RC2 : 902 – 905 Mhz / RC4: 920 -923 Mhz, 22 dBm
- **LoRaWAN™ dual Band:** AU915: 915-917 Mhz / US915: 902-9928 Mhz, 22 dBm
USA 902-928 Certified AU915-928 Certified LoRaWAN Specification Version: V1.0.4
LoRaWAN Regional Parameters Version: RP002-V1.0.1

Datalog X-PRO 2.0 EU

- **Module:** SJI LSM100A
- **Manufacturer:** SEONGJI
- **Sigfox** RC1: 868.13 ± 0.096 Mhz, 14 dBm ERP
- **LoRaWAN™ Band:** EU868: 863 - 870 Mhz, 14 dBm
EU863-870 Certified LoRaWAN Specification Version: V1.0.2 LoRaWAN Regional
Parameters Version: RP002-V1.0.2rB

Global Headquarters

America Regional Office

Omicron IoT Solutions

Address: La Amalita Km4 Llanogrande-Rionegro Mall Plaza del Sol Off. 202 Rionegro, Antioquia, Colombia.

Phone: +57 (604) 4087542

WhatsApp +57 (317)4365062

comercial@omicroning.co

www.omicroniot.com



© 2023 Omicron IoT Solutions. All rights reserved.